

correa

FOX

Bridge type milling machine

WARRANTY



**Nicolás Correa**, founded in Spain in 1947, is one of world's leading companies in the manufacturing of large milling machines. With over 900 bridge type machines, 1000 floor type machines and 3500 bed type machines installed all over the world, offers milling solutions designed for the most demanding production environments, such as the power generation, automotive, aerospace and railway industries.

**Nicolás Correa** is the parent company of **Correa Group** composed of four industrial subsidiaries linked to the machine tool sector: Hypatia, Steelworks, Electrónica and Kunming. The Group has commercial subsidiaries in China, Germany, United States, and India with the aim to offer the best service in all countries. Belonging to the group provides **Nicolás Correa** with access to top quality critical supplies and offers tailored solutions especially designed for each customer's needs.

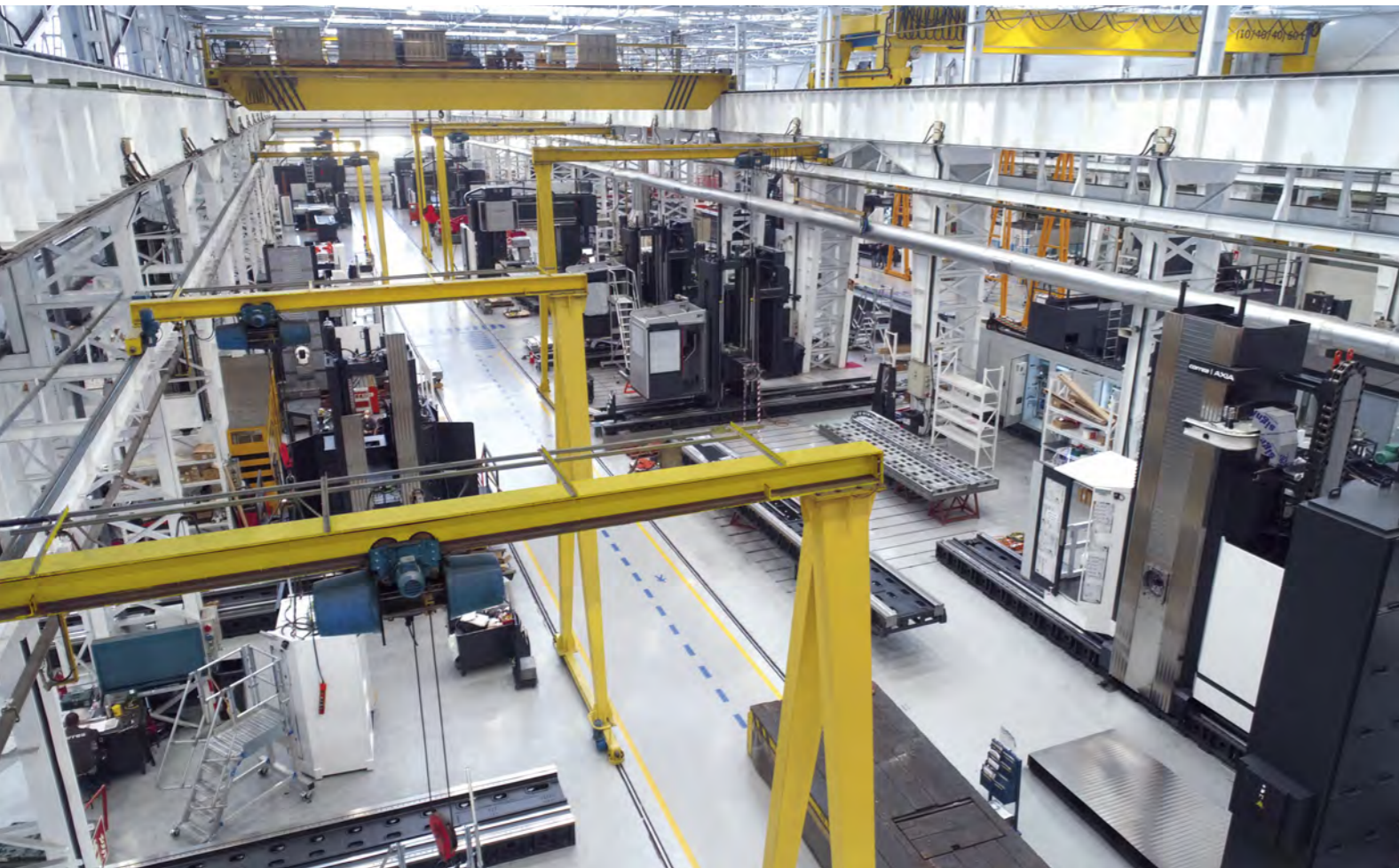

Thousands of customers around the world place their trust in **correa** range of milling machines. **Correa Group** currently exports around 90% of its production to over 30 different countries. To guarantee a high-quality service to our customers, we have an extensive international commercial and technical service network in most of the world's countries. **Correa Group** offers the widest range of milling solutions on the market, including bed type machines, gantry, floor type machines, bridge type machines, it also has a several options of multi-tasking machines. The entire range is designed and manufactured in Spain. **Nicolás Correa, S.A.** has been listed on the Madrid Stock Exchange since 1989.

The **FOX** combines traditional roughing capacity with the speed and precision of high performance machining controlling in real time the temperature generated in the Z axis.



HIGH DAMPING CAPACITY

- Vertical axis with water-cooled friction.
- Excellent damping capacity.
- Optimum performance with the ram in the lowest position.

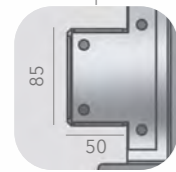

THERMO SYMMETRICAL DESIGN

- Totally symmetric design of vertical axis.
- Improved geometry of the machine.
- Geometry is more stable faced with temperature changes.

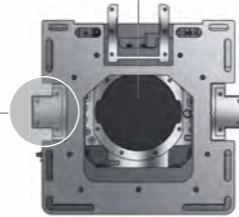

Ram Cross Section: 540 mm x 550 mm

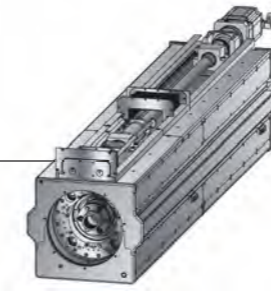

Crossbeam Cross Section: 1030 mm x 1305 mm



OVERSIZED STRUCTURAL ELEMENTS



HIGH GEOMETRICAL PRECISION

Double mechanical pull stud system. It avoids the use of electronic corrections and allows a fine mechanical adjustment that minimises angular errors at the tool tip.

The biggest cross sections in the market  
Roughing capacity  
Machine geometry stability

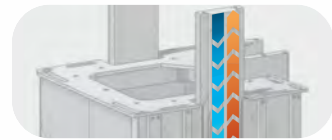

Cooled friction guide in the ram



VERTICAL AXIS TEMPERATURE CONTROL

- High feed.
- High precision at tool tip.
- High roughing capacity.
- Geometric stability of ram.

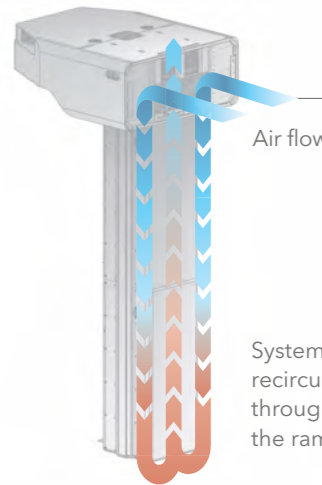

Air flow

System of air recirculation through the ram



Column Cross Section: 1100 mm x 1100 mm

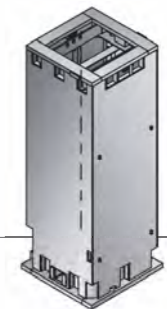

Cement filled columns for optimum damping



1390 mm

415 mm

MORE ABOUT THE FOX



Dynamic performance parametrizable in accordance with:

- ROUGHING OPERATION
- FINISHING OPERATION



MACHINE DYNAMIC ADJUSTMENT



MACHINING SETTINGS

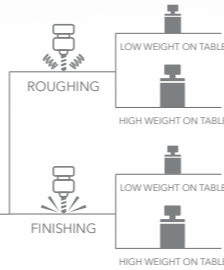

30 m/min in X, Y and Z axes, thanks to its V-Shaped linear guide-ways in all axes



HIGH FEED RATES



ECO DESIGN

Stand-by function and Auto Switch off function, saving 20% of the total energy machine consumption

## Technical Features

FOX 30 FOX 40 FOX 50 FOX 60 FOX 70 FOX 80

### TABLE

Surface	3500 x 2000 / 2500	4500 x 2000 / 2500	5500 x 2000 / 2500	6500 x 2000 / 2500	7500 x 2000 / 2500	8500 x 2000 / 2500	mm
Maximum load on the table	15 / 25						t

### TRAVERSES

Longitudinal [X]	3000	4000	5000	6000	7000	8000	mm
Cross [Y]	Cross: 3000 - 3750 - 4250 / DBC: 2500 - 3250 - 3750						mm
Vertical [Z]	1000 / 1500 / 1750						mm

### FEEDS

Maximum [X]	30	m/min
Maximum [Y]	30	m/min
Maximum [Z]	30	m/min

### SPINDLE SPECIFICATIONS

Spindle nose	ISO-50 Big Plus / HSK-100	
Programmable speed	10000 / 6000 / 6000	rpm
Maximum power	42 / 37 / 52	kW
Maximum torque	620 / 1298 / 1375	Nm

## External Dimensions

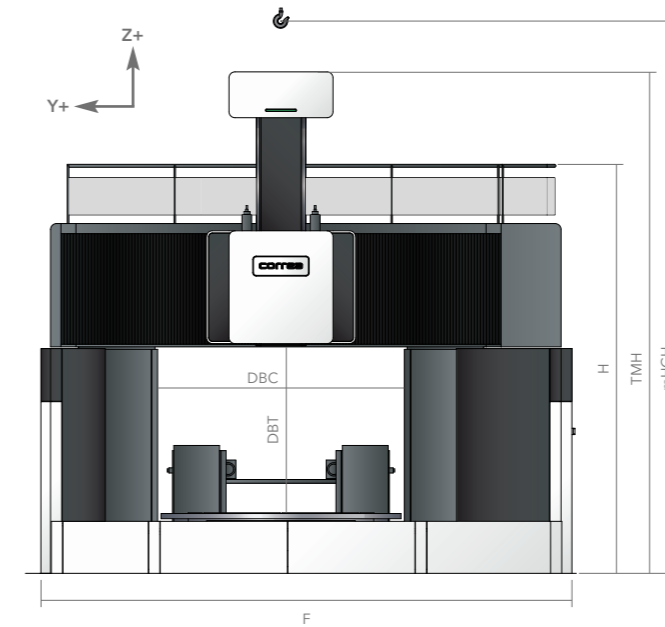

X Axis  
C

FOX 30	11250
FOX 40	13250
FOX 50	15250
FOX 60	17250
FOX 70	19750
FOX 80	22250

\* Only for full & perimeter guarding options

Y Axis	DBC	F
3000	2500	6400
3750	3250	7150
4250	3750	7650

Z Axis	Vertical capacity	DBT	H	TMH	mHCH
1000	A	1700	5050	5800	7060
	B	1950	5300	6050	7310
1500	C	2200	5550	6800	7560
	D	2450	5800	7050	7810
1750	D	2450	5800	7300	8060
	E	2700	6050	7550	8310

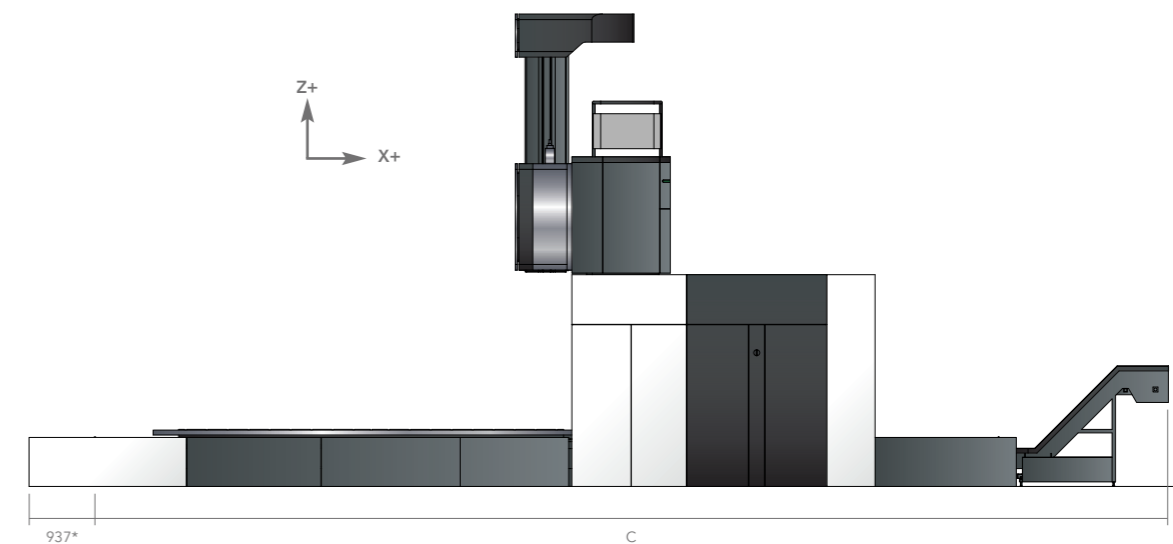

937\*

**FOX**

Bridge type milling machine



## Milling Heads



### UAD 0.02° x 0.02°

Universal Auto-Indexing  
Differential Head  
37 kW | 1298 Nm | 6000 rpm  
52 kW | 1375 Nm | 6000 rpm



### OAD 0.02° x 0.02°

Orthogonal Auto-Indexing  
Differential Head  
37 kW | 1298 Nm | 6000 rpm  
52 kW | 1375 Nm | 6000 rpm



### FC-30 | 60 | 80

Front Spindle  
15 • 37 kW | 1298 Nm | 3000 • 4000 rpm  
15 • 52 kW | 1375 Nm | 3000 • 4000 rpm



### FCT

High Torque Front Spindle  
37 kW | 1893 Nm | 4000 rpm  
52 kW | 2005 Nm | 4000 rpm



### FD-30 | 60 | 80

Non-centered front spindle  
15 • 37 kW | 1298 Nm | 3000 • 4000 rpm  
15 • 52 kW | 1375 Nm | 3000 • 4000 rpm



### AL-600 2.5°

Reach-out Angle Milling Head  
25 kW | 800 Nm | 1500 rpm



### UCE Universal

2-Axis Continuous Milling Head  
24000 rpm



### UT-500 | 630

D'Andrea Head  
37 kW | 7788 Nm | 315 • 250 rpm  
52 kW | 8000 Nm | 315 • 250 rpm



### CSE

2-Axis continuous Milling Head  
37 kW | 371 • 707 Nm | 4000 rpm



### UDX 0.02° x 0.02°

Universal Auto-Indexing Head  
42 kW | 620 Nm | 10000 rpm



### ESE Continuous

2-Axis continuous Milling Head  
35 • 60 kW | 12000 • 24000 rpm



### TU 2.5°

Turning and shaping Head

## Milling Head Changer



## Standard Equipment

- Automatic Universal Head • Hydraulic and cooling group
- Numerical control Heidenhain or Siemens [operate HMI] • Linear scales in all axes
- Portable handwheel • Exterior coolant with adjustable lance nozzles
- Air-conditioned electrical cabinet • Internal and external air flow
- Linear guides in the X, Y axes • Guarding
- Lamp in the working area • Friction guide at Z axis
- Tele-service

## Optional Equipment

- Other heads • Vixion 4.0
- Automatic head-changer • Self cleaning filter
- Pick up station for 6, 8 and 12 tools • Air/Coolant cleaning gun
- Automatic charger for 30, 40, 60 and 120 tools • Chip conveyors
- Probes of measurement, tools and parts • Perimeter fence
- Turning table • Integral guarding [only in some models]
- Rotary tables • Coolant through the spindle
- Zero-point systems for rapid part change • Automatic pallet changer



MULTITASKING

**correa** multitasking machines combine several cutting processes on one machine. These machines offer the manufacturing capabilities of milling and turning machines into one integrated unit to use the functionality of both simultaneously.

## UAD T

The universal head **UAD T** incorporates a spindle internal brake to lock the spindle axis. This solution allows to rotate the turning tool to any position and lock the spindle accordingly. This is a mechanical transmission head providing a perfect integration between milling and turning.



### General Specifications

Tool holder HSK-100 for both milling and turning tools. In case of turning tools HSK-100T is required.

**Milling mode:** 6000 rpm and rotation every 0.02° in both bodies.

**Turning mode:** Rotation every 0.02° in both bodies.

## TU

Orthogonal turning head **TU** rotates every 2.5° thanks to the crown hirth coupling allows to position the tools. We can use neutral tools for turning providing the angel with the head position, reducing the number of tools needed.



### General Specifications

Tool holder Capto C8.

Rotation every 2.5° to reduce the number of turning tools to be used.

Automatic tool changing.

## TU 25

Turning head **TU 25** incorporates two tapers to 90°. The two tapers offer flexibility to perform several facing and turning operations on a workpiece.



### General Specifications

Tool holder Capto C8.

Double two tapers to 90°.

Manual tool change.

	Material	Ø (mm)	Ap (mm)	Vc (m/min)	F (mm/min)	Q (cm³/min)
Medium Duty Roughing	Ck-45 (60 kg/mm²)	1090	4.5	210	0.5	471
Heavy Duty Roughing	Ck-45 (60 kg/mm²)	1200	10	210	0.7	1450

## TUB

For internal turning operations in deep parts, Nicolás Correa has specifically designed a manual extension which includes a tuned mass absorber (TMA) internally for a better cutting performance.

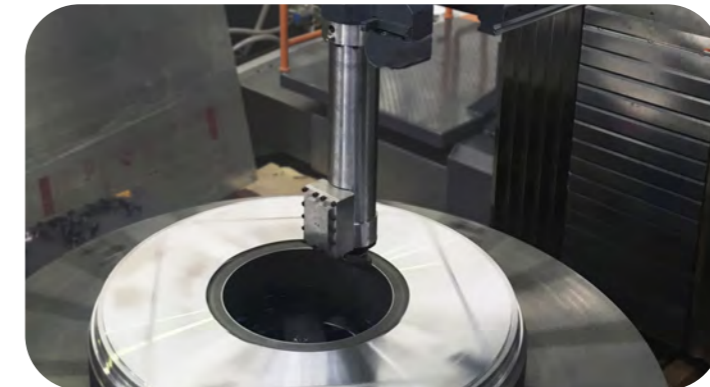

## TURNING TABLE INTEGRATED IN X AXIS

	Ø 2000 mm	Ø 2000 mm	Ø 2500 mm	
Maximum load milling/turning	5 - 10 - 20	5 - 10 - 20	5 - 10 - 20	t
Speed	250 - 250 - 150	250 - 250 - 150	250 - 250 - 150	rpm





# correa

[www.nicolascorrea.com](http://www.nicolascorrea.com)

## Nicolás Correa, S.A.

Alcalde Martín Cobos, 16-A  
09007 Burgos • Spain

Phone: +34 947 288 100

Fax: +34 947 288 117

[correa@correa.es](mailto:correa@correa.es)

