

correa

NORMA L

Travelling column milling machine

WARRANTY



Nicolás Correa, founded in Spain in 1947, is one of world's leading companies in the manufacturing of large milling machines. With over 900 bridge type machines, 1000 floor type machines and 3500 bed type machines installed all over the world, offers milling solutions designed for the most demanding production environments, such as the power generation, automotive, aerospace and railway industries.

Nicolás Correa is the parent company of **Correa Group** composed of four industrial subsidiaries linked to the machine tool sector: Hypatia, Steelworks, Electrónica and Kunming. The Group has commercial subsidiaries in China, Germany, United States, and India with the aim to offer the best service in all countries. Belonging to the group provides **Nicolás Correa** with access to top quality critical supplies and offers tailored solutions especially designed for each customer's needs.

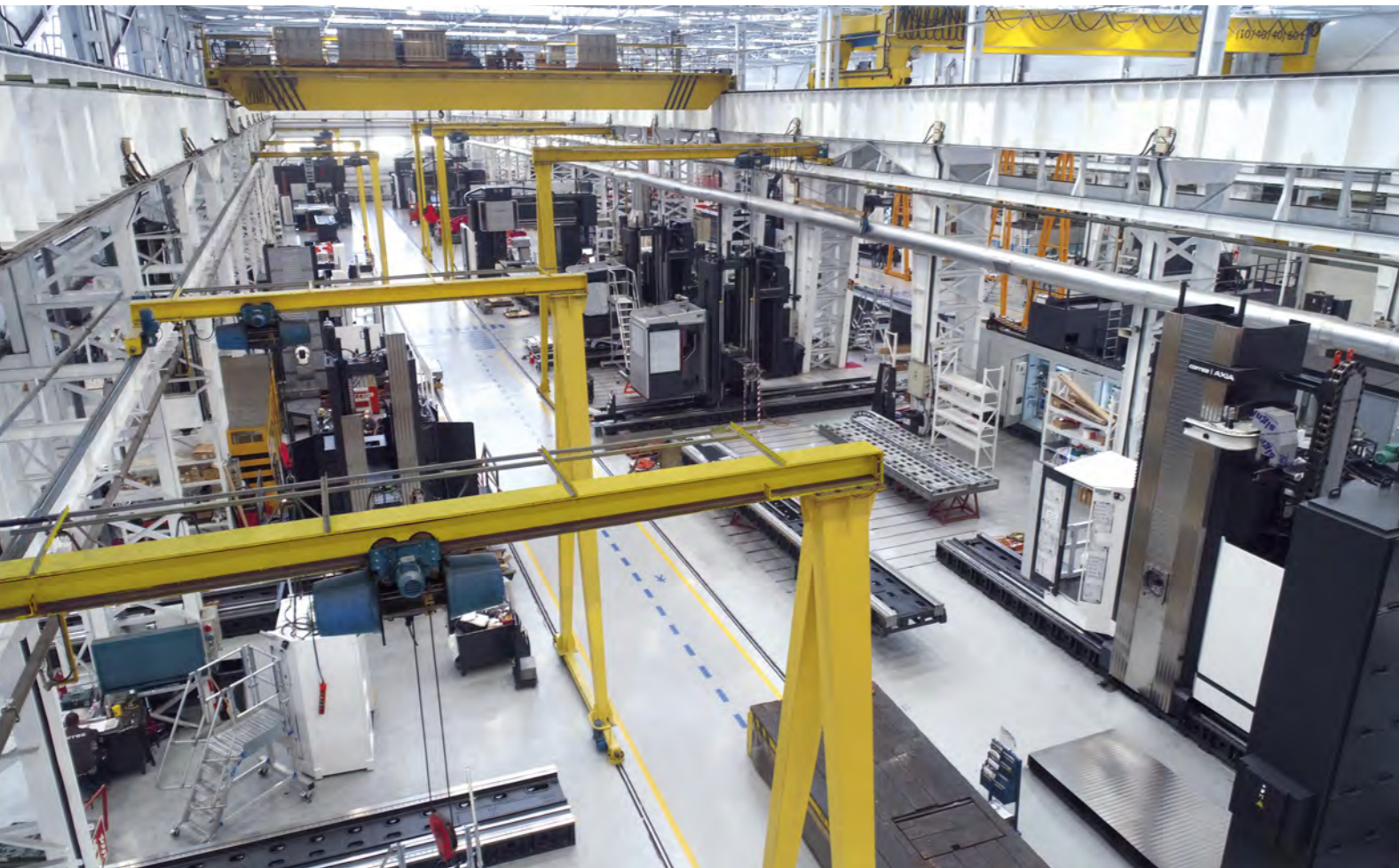

Thousands of customers around the world place their trust in **correa** range of milling machines. **Correa Group** currently exports around 90% of its production to over 30 different countries. To guarantee a high-quality service to our customers, we have an extensive international commercial and technical service network in most of the world's countries. **Correa Group** offers the widest range of milling solutions on the market, including bed type machines, gantry, floor type machines, bridge type machines, it also has a several options of multi-tasking machines. The entire range is designed and manufactured in Spain. **Nicolás Correa, S.A.** has been listed on the Madrid Stock Exchange since 1989.

The **NORMA L** represents a new concept in mobile column machine with lateral ram. Very sturdy thanks to the L-shaped ram guide and triple X-axis guide. Precision thanks to the mechanical ram droop correction system. A flexible machine suitable for machining and finishing operations.



L-GUIDE-WAY SYSTEM CONFIGURATION

- L-shaped guide system:
 - Greater rigidity and stability during machining.
 - Greater geometrical precision.
 - Less ram droop effect.
- 6 vertical movement sliders ensuring good machine behaviour.

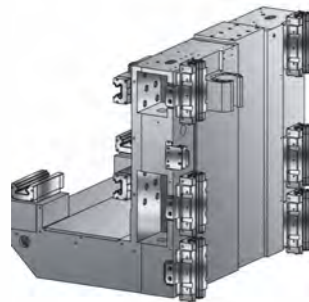
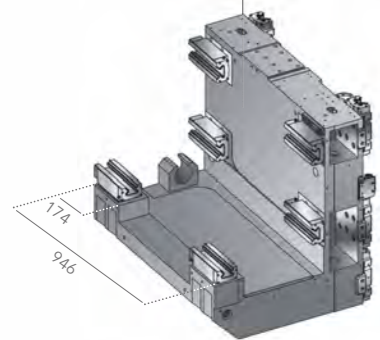

MORE ABOUT THE **NORMA L**



Dynamic performance parametrizable in accordance with:

- ROUGHING OPERATION
- FINISHING OPERATION



MACHINE DYNAMIC ADJUSTMENT

MACHINING SETTINGS

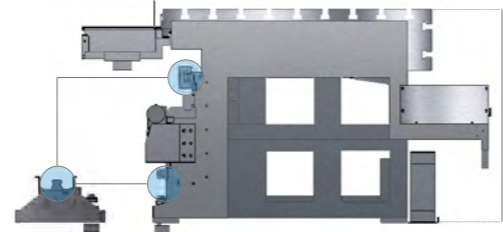

3 moving X-axis guides to ensure stability and good geometrical precision.



MECHANICAL COMPENSATION SYSTEM

Traction bars to eliminate the angular error of the ram droop effect.

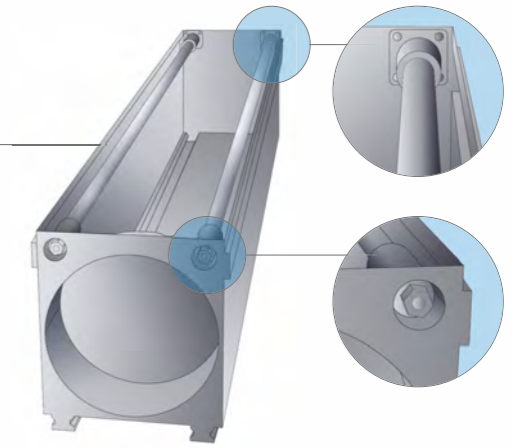

The largest cross-sections on the market.

High machining capacity + geometrical stability over time.



OVERSIZED STRUCTURAL ELEMENTS



HIGH GEOMETRICAL PRECISION

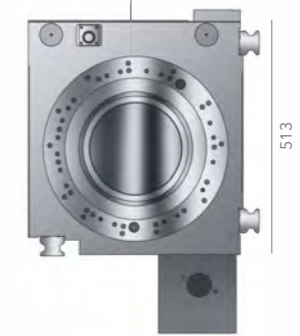

30 m/min in X, Y and Z axes, thanks to its V-Shaped linear guide-ways in all axes.



HIGH FEED RATES



ECO DESIGN

Stand-by function and Auto Switch off function, saving 20% of the total energy machine consumption.

Technical Features

NORMAL 45

NORMAL 60

NORMAL 80

TABLE

Table width	5500 / 1200	7000 / 1200	9000 / 1200	mm
Maximum load on the table	10			t/m ²

TRAVERSES

Longitudinal [X]	4500 / 6000 / 8000			mm
Cross [Y]	1250 / 1500			mm
Vertical [Z]	1500 / 2000			mm

FEEDS

Maximum [X]	30	m/min
Maximum [Y]	30	m/min
Maximum [Z]	30	m/min

SPINDLE SPECIFICATIONS

Spindle nose	ISO-50 Big Plus / HSK-100		
Programmable speed	4000 / 6000 / 10000	rpm	
Maximum power	24 / 33 / 30	kW	
Maximum torque	840 / 990 / 620	Nm	

External Dimensions

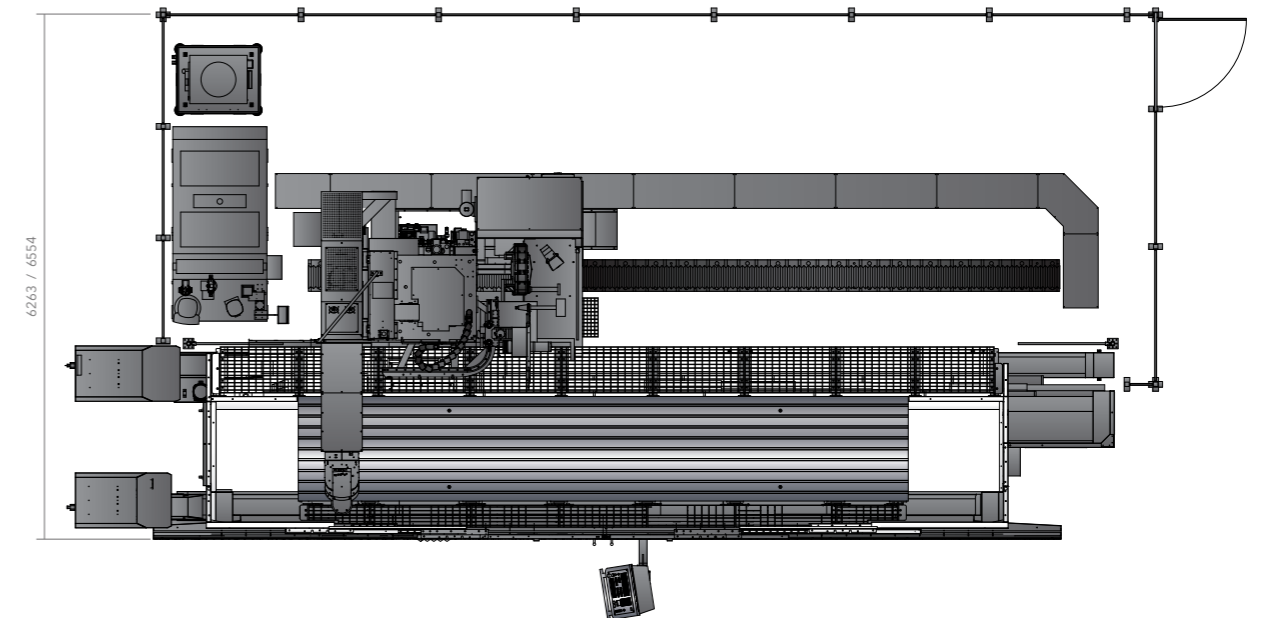
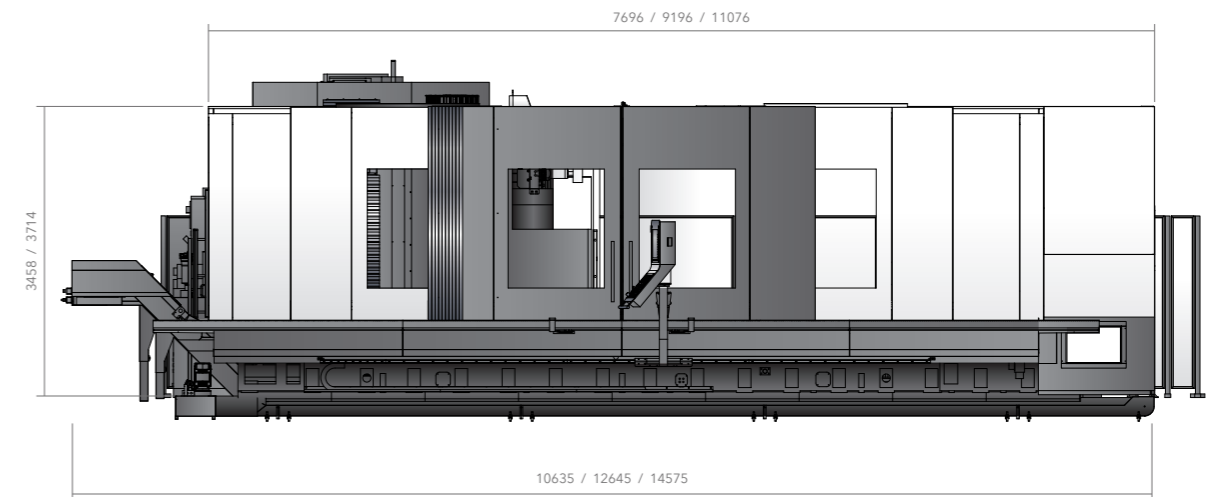

NORMA L

Travelling column milling machine

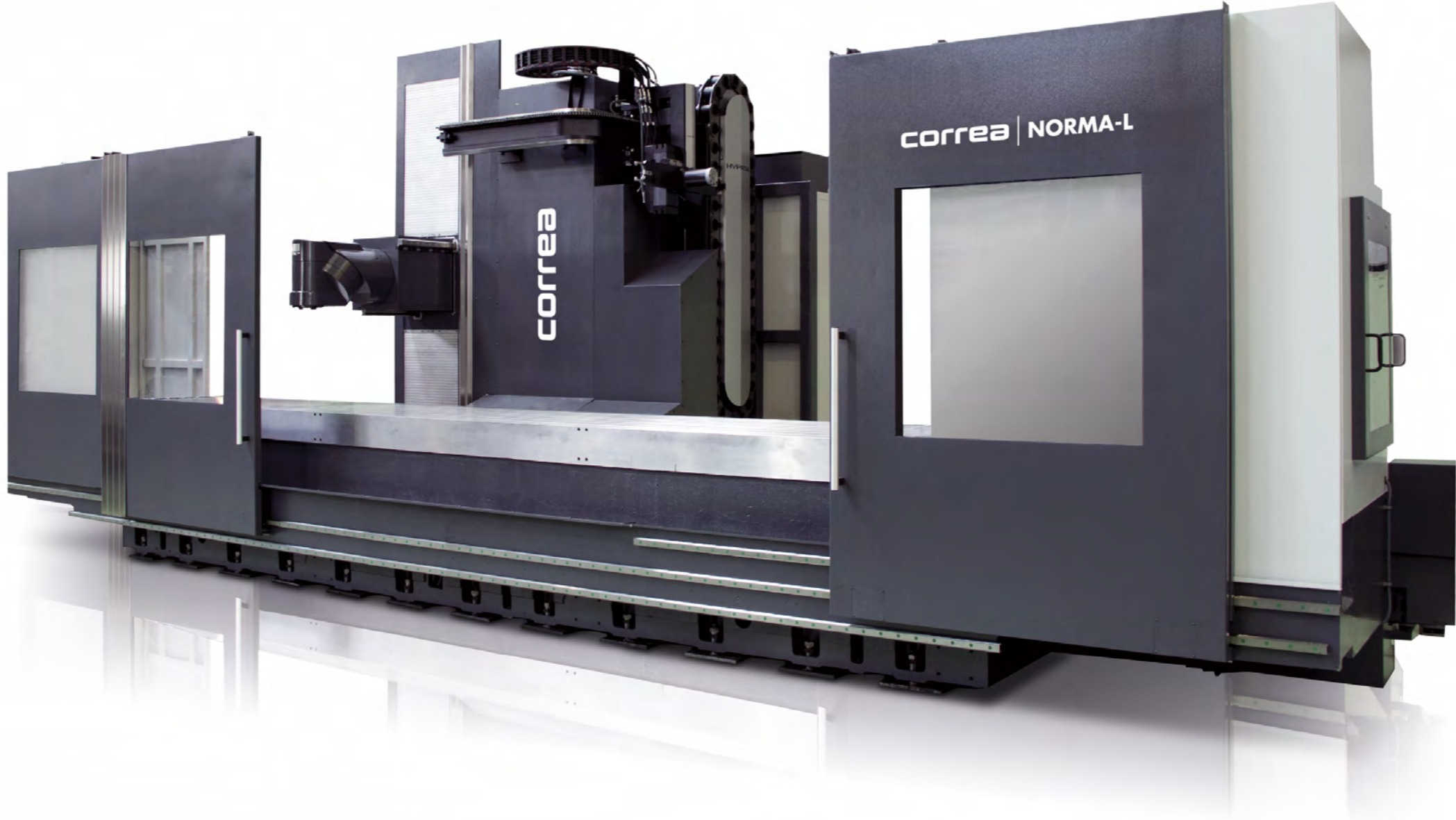

Milling Heads

UAD • UAD T 0.02° x 0.02°



Universal Auto-Indexing
Differential Head
24 kW | 840 Nm | 6000 rpm
33 kW | 990 Nm | 6000 rpm



UDX 0.02° x 0.02°

Universal Auto-Indexing Head
30 kW | 620 Nm | 10000 rpm



OAD 0.02° x 0.02°

Orthogonal Auto-Indexing
Differential Head
24 kW | 840 Nm | 6000 rpm
33 kW | 990 Nm | 6000 rpm

UDG 2.5° x 2.5°



Universal Automatic Head
24 kW | 840 Nm | 4000 rpm
33 kW | 990 Nm | 4000 rpm

Standard Equipment

- Automatic Universal Head • Gearbox
- Numerical control Heidenhain TNC 640 • Hydraulic group
- Portable handwheel • Linear scales in all axes
- Air-conditioned electrical cabinet • External Coolant with adjustable nozzles
- Linear guides in the X, Y and Z axes • Perimeter fence
- Lamp in the working area • Direct Tele-service

Optional Equipment

- Other heads • Vixion 4.0
- Pick up station for 8 tools • Air or oil cleaning gun with motor pump
- Automatic charger for 30, 40 and 60 tools • Coolant through spindle to high and medium pressure
- Probes of measurement, tools and parts • Centrifugal filter in cutting fluid tank
- Rotary tables • Chip conveyors
- Integrated rotary tables • Integral guarding
- Pendular working system • Operator cabinet



MULTITASKING

correa multitasking machines combine several cutting processes on one machine. These machines offer the manufacturing capabilities of milling and turning machines into one integrated unit to use the functionality of both simultaneously.

UAD T



The universal head **UAD T** incorporates a spindle internal brake to lock the spindle axis. This solution allows to rotate the turning tool to any position and lock the spindle accordingly. This is a mechanical transmission head providing a perfect integration between milling and turning.

General Specifications

Taper: HSK-100 for both milling and turning tools. In case of turning tools HSK-100T is required.

Milling mode: 6000 rpm and rotation every 0.02° in both bodies.

Turning mode: Rotation every 0.02° in both bodies.

	Material	Ø (mm)	Ap (mm)	Vc (m/min)	F (mm/min)	Q (cm³/min)
Medium Duty Roughing	Ck-45 (60 kg/mm²)	1090	4.5	210	0.5	471

TUB

For internal turning operations in deep parts, Nicolás Correa has specifically designed a manual extension which includes a tuned mass absorber (TMA) internally for a better cutting performance.

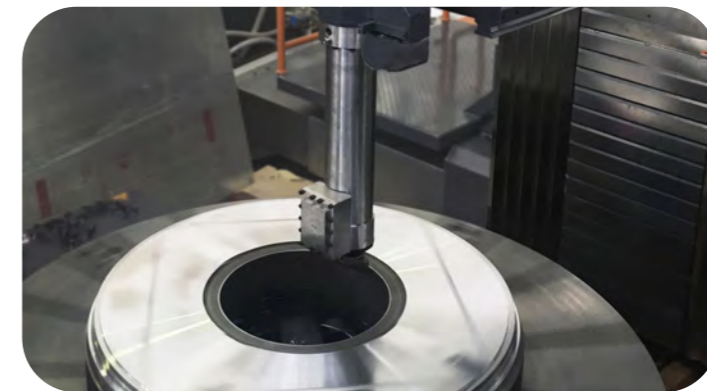

TURNING ROTARY TABLE

	Ø 1600 mm	Ø 2000 mm	
Maximum load	8 - 6	8 - 5	t
Speed	250	250	rpm



NORMA L

Travelling column milling machine

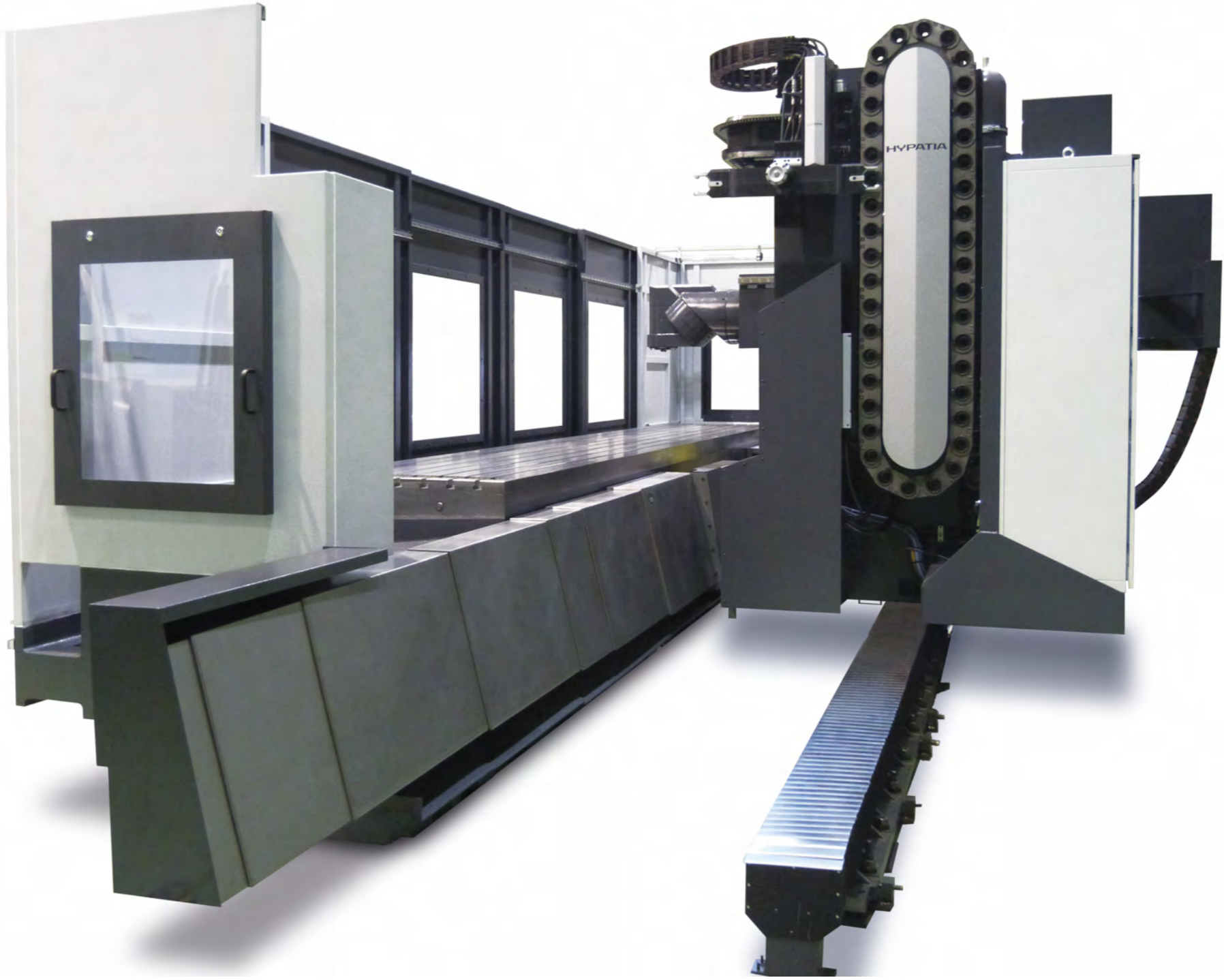

correa

www.nicolascorrea.com

GNC Hypatia

Condado de Treviño, 53
09001 Burgos • Spain
Phone: +34 947 298 528
Fax: +34 947 473 520
info@gnchypatia.com

Nicolás Correa, S.A.

Alcalde Martín Cobos, 16-A
09007 Burgos • Spain
Phone: +34 947 288 100
Fax: +34 947 288 117
correa@correa.es

