

GSA+

GSA TECHNOLOGY CO., LTD.

CNC Rotary Table



GSA+

GSA TECHNOLOGY CO., LTD.

No. 81, Alley 67, Lane 66, Feng-Nan St.
Feng-Yuan, Taichung, Taiwan

TEL: +886-4-2537 7888

FAX: +886-4-2536 8899

E-mail:goldensn@ms7.hinet.net

<http://www.gsaplus.com.tw>



GSA+

- GSA TECHNOLOGY CO., LTD. established in 1978, from time to time, our growing of devotion work stable, keeping in mind of honesty, faith, profession and innovation, non-stop communication and promotion of critical quality procedure, ensure every products could meet high quality of duration and precision.
- Further we display our products at IMTS-Chicago, EMO-Hannover, JIMTOF-Tokyo and TIMTOS-Taipei, and receiving reputation from the customer of the worldwide.
- To meet the request of customer, both upgrading the quality of our produces and purchasing new machinery of testing and inspection, collecting update technology to develop value-added products.
- The sales & service had been built around the network of worldwide, technical supporting and customer service are connected through our agents and dealers more than 30 countries of the world.
- We stay improving and innovating our products as the goal of never ending story, the satisfied of our customer and continuing devotion of our products are what working for the mutual benefits of our customers and members of GSA.



TIMTOS-Taipei



EMO-Hannover



CIMT-Beijing



JIMTOF-Tokyo



IMTS-Chicago



ELECTRON PANEL-Production management



MARKETING & SALES MANAGEMENT



AFTER SALES SERVICE

Perfect and strong service team members with excellence professional technique

- 1978 Company established, started product of Precision-Index-Tables
- 1980 Professional manufacturer of Precision-Feed-Index-Tables
- 1985 Cooperated with vendors in Switzerland, Germany, Japan & USA
- 1988 Products No. 1 awarded MCS (Mechanical Components Standards)
Professional manufacturer of CNC-Rotary-Table
- 1990 Built a new Factory 4,290m² of production-line 1,500m²
Phase-in products A/M-Pallet-Changer, CNC-Tilting-Rotary-Table
- 1992 Organized and set up branch office in Shanghai, China
- 1994 Products awarded "Symbol of Excellence winner"
- 1996 Certificate approved of ISO-9001 by TÜV Rheinland, Germany Products
awarded again the "Symbol of Excellence winner"
- 1997 Release new series of Tool-Turret for CNC Lathe
- 1999 Ready to again Y2K and carry out ERP in whole factory
- 2000 Complete second factory building
To set up service center in Shanghai, China
- 2003 To expand factory buildings to 7,600m²
- 2004 OEM power milling turret and servo drive turret designed by Japan
- 2006 Complete development of power turret
- 2007 Import Germany made CNC Hobbing machine (P600/800) from GLEASON PFAUTER
- 2008 Transferred the name of Golden Sun Industrial Co., Ltd to GSA TECHNOLOGY CO., LTD.
specialize in manufacturing CNC Rotary Table and Turret which has built new factory land to 15,000m²
- 2009 Implementation of 5S for workplace improvement
- 2010 Acquired Germany Made 5 Axes Milling Machine and 5-Face Double Column Machining Center
- 2011 Implementation of T.O.C(Theory of Constraints) to reach goal of QCD(Quality, Cost, Delivery)
- 2012 To build China new factory (Jiashan, Shanghai) 20,000m²
- 2015 China new factory (Jiashan, Shanghai) finished, start to build Taiwan Houli factory

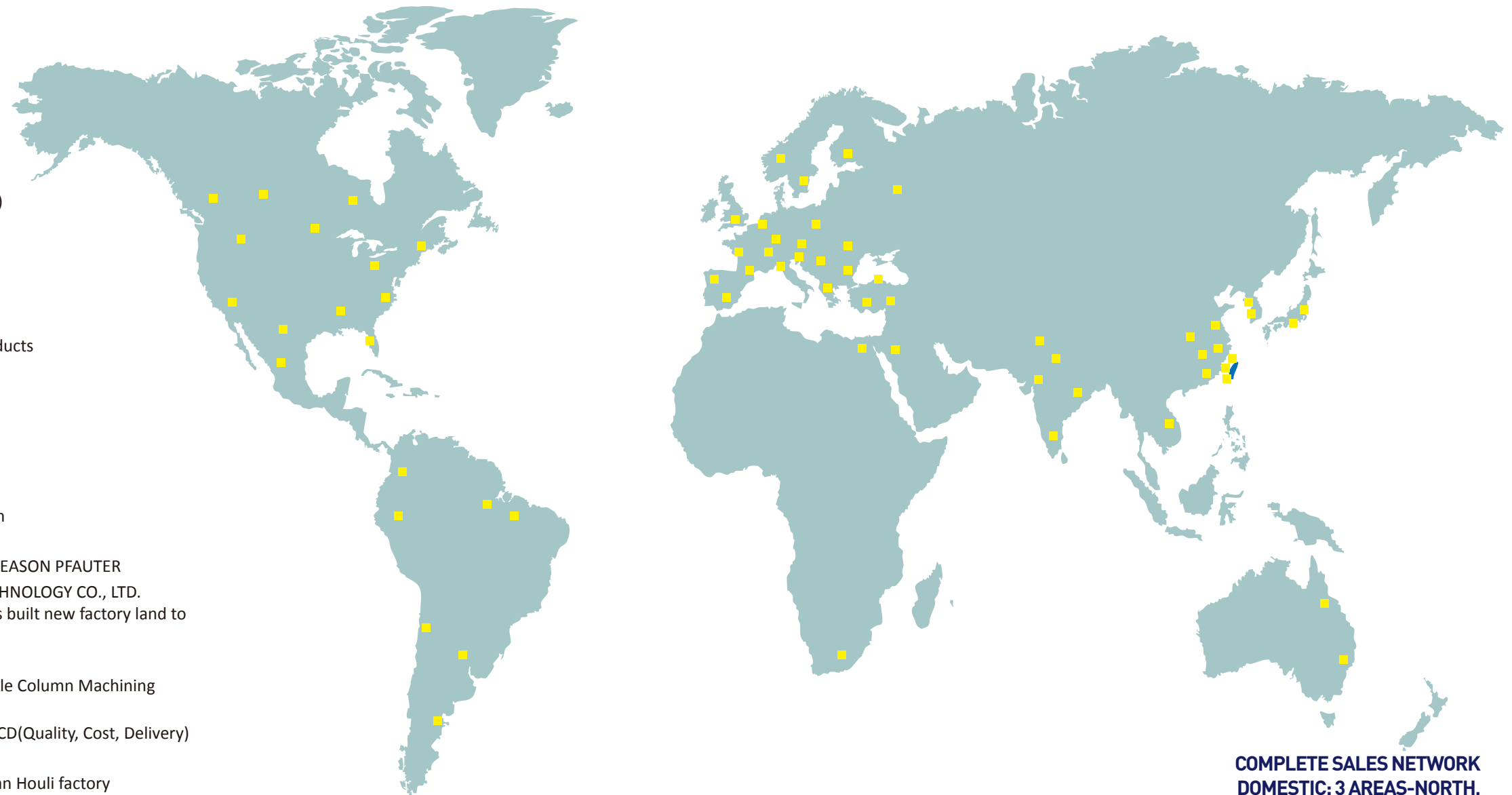

COMPLETE SALES NETWORK
DOMESTIC: 3 AREAS-NORTH, MIDDLE, SOUTH-TAIWAN
OVERSEA: AGENT & DEALERS SPREAD OUT 40 COUNTRIES OF THE WORLD

IDEAL PERFORMANCE HIGH EFFICIENCY GREAT DURABILITY

with Excellent Worm Gear System



Materials

Worm shaft : Case hardened alloy steel
Worm wheel : Special high tensile brass alloy equal to strength of a steel alloy

Efficiency of transmission torque

The combination of worm shaft and worm wheel makes the friction factor smaller and the efficiency of transmission torque larger

Tooth profile

The depth of tooth is larger in module of standard size

(I) The Matching Schema of Dual Lead Worm Wheel and Worm Shaft

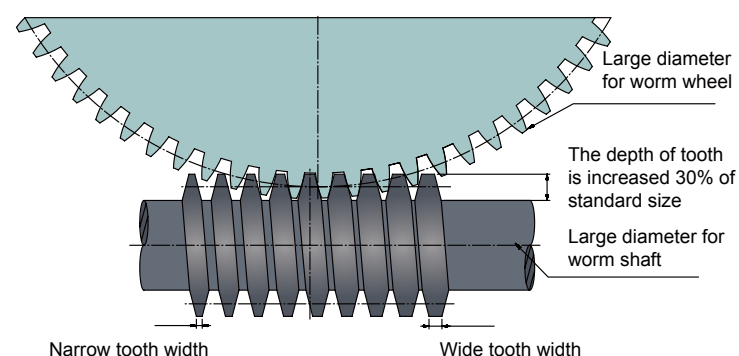

- Surface contact between in worm wheel and worm shaft can be reached 35%~45% suitable for heavy cutting and continuous processing
- Good wear-resisting, there is no need to adjust backlash at least 1~2 years
- Indexing accuracy class is maintained within 10 (sec.) (standard 15 sec.)

(II) Indexing Accuracy Class for CNC Rotary Table

HEIDENHAIN ACCOM

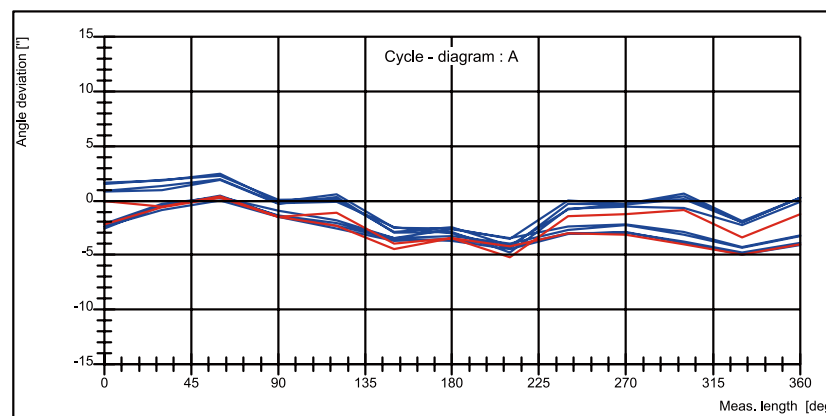

- Indexing accuracy class: 10(sec.) (standard 15 sec.)
- Repeatability: 4 (sec.)
- According to ISO 230.2 standard of inspection which can be qualified to Aeronautics and Military Industry.

(III) The Schema of Brake System Clamping force is increased 2~3 times if compare with other brands of company

- Multi-brake disc system designed (Clamping with 4 Sides Friction)
- Creating clamp torque 200 kg·m from pneumatic source : 5kg/cm²
- Compact & high durability designed; there is no lifting-up situation during rotating

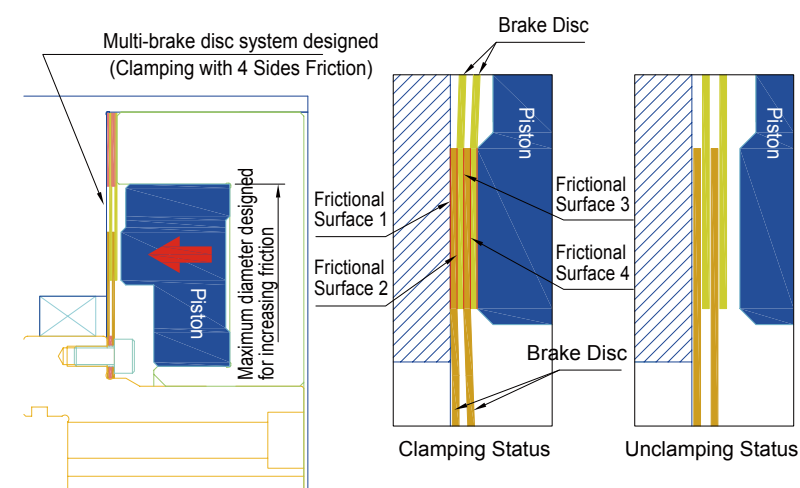

(V) Indexing Accuracy Class for Hirth Coupling

- Indexing accuracy class: ±3 (sec.)
- Repeatability: ±1 (sec.)
- Contact rate of Teeth surface can be reached 90%



(IV) The Schema of Advantage Bearing System

- 3 sides constraint designed, supporting force is greater than same dimension of Cross-Roller Ring (bearing) above 2 times
- Dual bearings designed, extending diameter suitable for heavy cutting

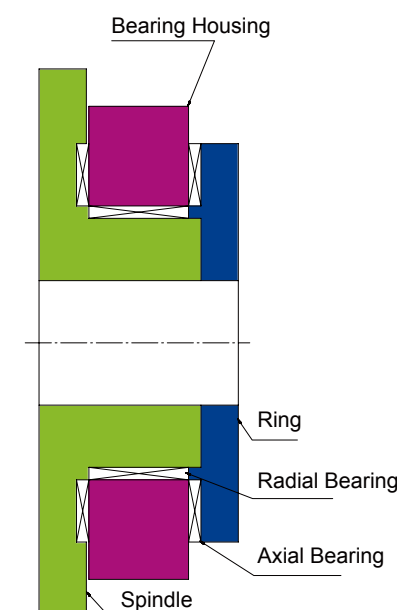

(VI) Gear Ratio

- To match high speed machine center (60m/min) with high speed CNC Rotary Table
- Gear ratio 90:1 can be reached 33rpm (motor:3000rpm)



GERMANY MADE GLEASON PFAUTER CNC HOBGING MACHINE

Adopting Germany made GLEASON PFAUTER CNC Hobbing machine (P600/800) for worm wheel machining, indexing accuracy class can be reached 5 (sec.) Accuracy class is conformed to DIN2 (same as JIS 0). Using built-in Direct Drive Motor designed in spindle of rotary table, there is no backlash situation.



CNC WORM SHAFT GRINDING MACHINIE

Adopting direct drive motor in spindle and other axes use linear motor for worm shaft machining. Inspecting accuracy can be reached 0.002mm anywhere in grinding.

Adopting Germany made DMG 5 Axes Turning / Milling / Grinding High-End Mahcine. Machining Job: High Precision Large Size Work-Piece. DIA. within 2,000mm.



Adopting Germany made DMG 5 Axes Milling Machine. Machine Job: Tool-Disc Machining from Roughing to Finish Mahcining.



Adopting CNC Horizontal Machining Center for Housing and Tool-Disc Maching.



Adopting 5-Face CNC Double Column Machining Center for Large Size Housing Machining.



Adopting OKUMA MA-60HB HMC fro Housing machining, the parallelism and perpendicularity in boring machining can be reached 0.005mm in between spindle hole and center hole of worm shaft.

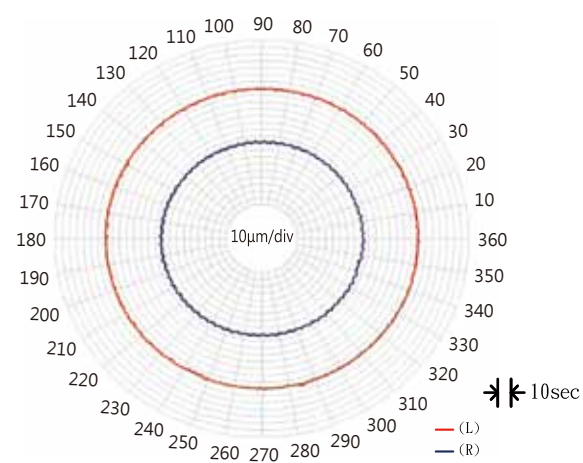

Suface contact and pitch error testing for worm gear system.



3D Measuring Machine from ZEISS Germany

- Featruce: Measure geometric accuracy error for all components.
- Accuracy: $1.9\mu + L/300\text{mm}$

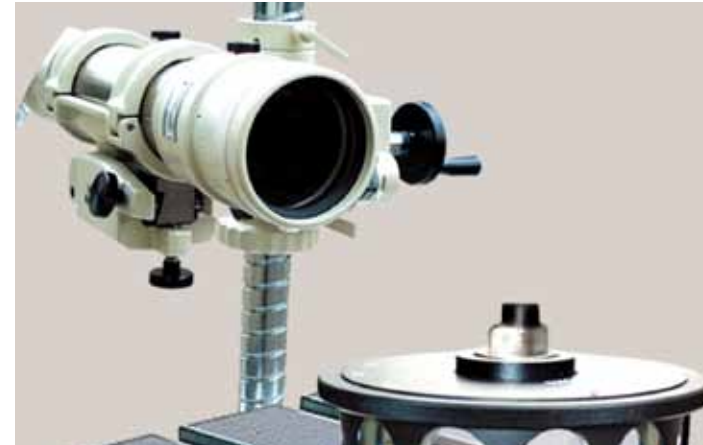

Autocollimator from Nikon Japan

- Featruce: Inspect angle accuracy and angle error.
- Accuracy: $\pm 1 \text{ arc sec.}$

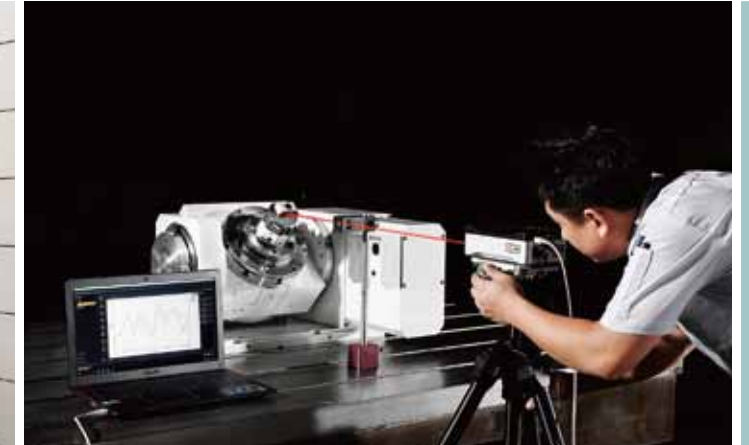

RENISHAW Two Axes Calibrator

- Featruce: Inspect 2 axes angle accuracy.
- Accuracy: $\pm 1 \text{ arc sec.}$

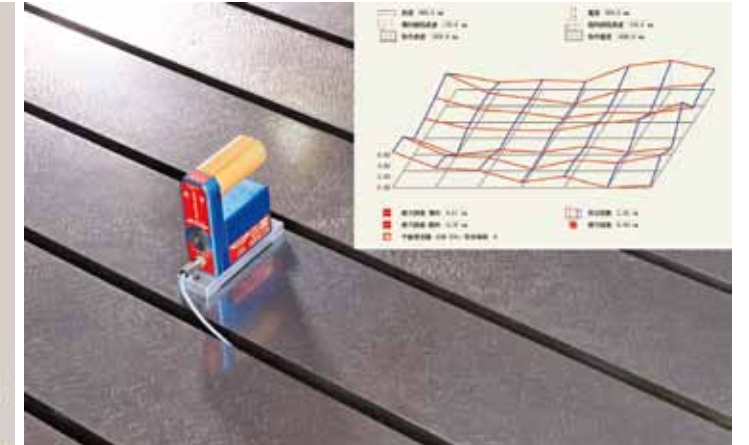

Electronic Level Device from Wyler Switzerland

- Featruce: Inspect top flatness of large size rotary table.
- Accuracy: 0.001 mm/m

SIMULATION & ANALYSIS TECHNOLOGY

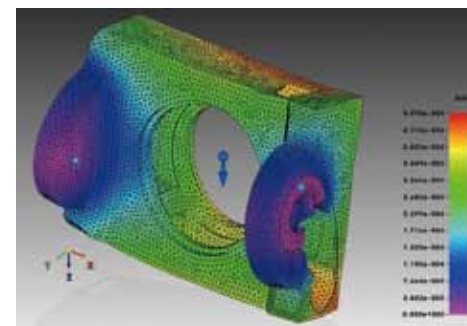

Displacement - Total Translation

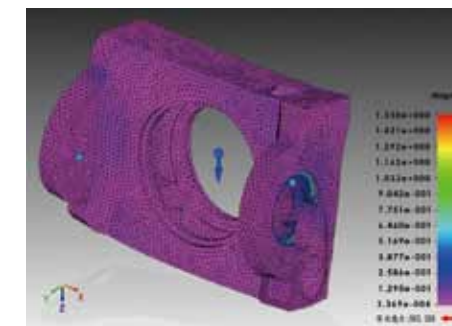

Stress - Von Mises

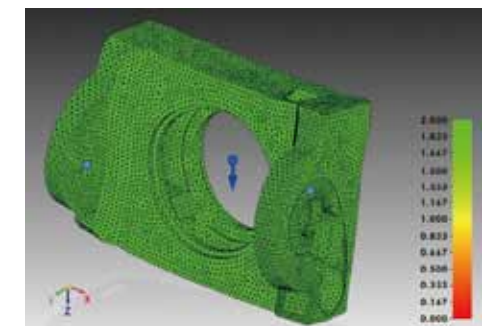

Stress - Safety Factor

INDEX

CNC

CNCB

CNCT / CNCMT

NCF

Tailstock

Large Size Table

GCT

PT

APCR / APCI

Controller

Coupling

Accessories

CNC

CNCB

CNCT / CNCMT

NCF

Tailstock

Large Size Table

GCT

PT

APCR / APCI

Controller

Coupling

Accessories

CNC

CNC Rotary Table **Satandard Type** P.13



CNC-120R	CNC-170R	CNC-200R
CNC-250R	CNC-320R	CNC-400R
CNC-500R	CNC-630R	CNC-800R

CNCB

CNC Rotary Table **Mega Thru Hole Type** P.17

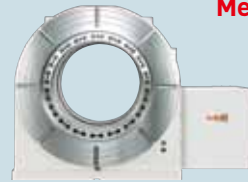

CNCB-800R

CNC

CNC Rotary Table **Back Mounted Motor Type** P.19



CNC-120RB	CNC-170RB
CNC-200RB	CNC-250RB

CNC

CNC Rotary Table **Multi-Spindle Type** P.21



CNC-120R ^{2W} / _{3W}	CNC-170R ^{2W} / _{3W}
CNC-200R ^{2W} / _{3W}	CNC-250R ^{2W} / _{3W}
CNC-320R ^{2W} / _{3W}	

Large Size Table **Large Size Horizontal CNC Rotary Table** P.40

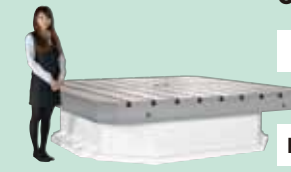

HRT-400	HRT-500	HRT-630
	HRT-800	HRT-1000
HRT-1500	HRT-2000	HRT-2500

Large Size Table **Heavy-Duty CNC Rotary Linear Table** P.43

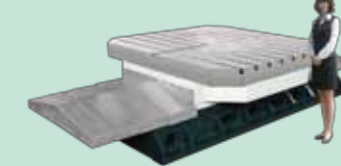

RLT-1500	RLT-2000
	RLT-2500

CNCT

CNC Tilting Rotary Table P.25



CNCT-100	CNCT-200
CNCT-250	CNCT-320

CNCT

CNC Trunnion Table P.27



CNCT-320RS	CNCT-450
CNCT-630	CNCT-800

Large Size Table **Large Size CNC Rotary Table** P.45



CNC-1000HV	CNC-1200HV	CNC-1500HV
CNC-2000HV		

GCT

Precision Index Table P.47



GCT-301	GCT-450
GCT-600	GCT-700
GCT-800	GCT-1000
	GCT-1200

PT

High Precision Center Table With Pallets P.49



PT-200	PT-340	PT-470
PT-600	PT-800	

APCR/APCI

Horizontal Machining Center Table With Pallets P.51



APCR/APCI 400	APCR/APCI 500	APCR/APCI 630
APCR/APCI 800	APCR/APCI 1000	

CNCMT

CNC Manual Tilting Rotary Table P.30



CNCMT-200	CNCMT-250
CNCMT-320	CNCMT-400
CNCMT-500	CNCMT-630

NCF

CNC Face Gear Indexer P.32



NCF-250R	NCF-320R
NCF-400R	NCF-500R

Controller AC Servo Controller P.53



Coupling Hirth Coupling P.56



Tailstock Manual Tailstock P.34



TS-A115	TS-A135	TS-A160
TS-B185	TS-B190	TS-B210
TS-B250	TS-B255	TS-B270
TS-C310	TS-C400	TS-C480

Tailstock Pneumatic Tailstock Hydraulic Tailstock P.35



TS-A115 ^P / _H	TS-A135 ^P / _H	TS-A160 ^P / _H
TS-B185 ^P / _H	TS-B190 ^P / _H	TS-B210 ^P / _H
TS-B250 ^P / _H	TS-B255 ^P / _H	TS-B270 ^P / _H
TS-C310 ^P / _H	TS-C400 ^P / _H	TS-C480 ^P / _H

Accessories Optional Accessories P.58



Application Application of Products P.61

Tailstock Strong Tailstock P.36



TSA-120S	TSA-200S
TSA-251S	TSA-320S

Large Size Table Horizontal Rotary / Index Center Table P.37



HIT-400	HIT-500
HIT-630	HIT-800



- ⊙ A combination of high precision bronze / nickel worm wheel and case hardened steel worm screw ensures long term indexing accuracy.
- ⊙ Dual lead worm wheel/worm shaft which allow easy backlash adjustment.
- ⊙ Double bearing design suitable for heavy cutting.
- ⊙ One piece of faceplate and spindle design which offer rigid construction.
- ⊙ Low Gear ratio design (90:1) which offer high speed feed rate.
- ⊙ **Large thru hole design** which allow large work piece going thru spindle.

MODEL NO : CNC-320 R/L

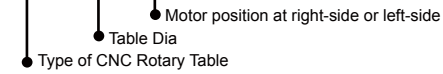

ITEM / MODEL		CNC-120R	CNC-170R	CNC-200R	CNC-250R	CNC-320R
Table Dia (mm/inch)		120 / 4.72	170 / 6.69	200 / 7.87	250 / 9.84	320 / 12.60
Center Height in Vertical (mm / inch)		115 / 4.53	135 / 5.31	160 / 6.3	185 / 7.28	210 / 8.27
Table Height in Horizontal (mm / inch)		170 / 6.69	165 / 6.5	165 / 6.5	200 / 7.87	240 / 9.45
Over all Height in Vertical Without Motor Cover (mm / inch)		193 / 7.60	240 / 9.45	265 / 10.63	315 / 12.4	380 / 14.96
Thru-Hole Dia (mm / inch)		30 ^{H7} / 1.18 ^{H7}	35 ^{H7} / 1.37 ^{H7}	35 ^{H7} / 1.37 ^{H7}	70 ^{H7} / 2.75 ^{H7}	110 ^{H7} / 4.33 ^{H7}
Width of T-slot (mm / inch)		10 ^{H7} / 0.39 ^{H7}	12 ^{H7} / 0.47 ^{H7}	12 ^{H7} / 0.47 ^{H7}	12 ^{H7} / 0.47 ^{H7}	14 ^{H7} / 0.55 ^{H7}
Width of Guide Block (mm / inch)		14 ^{H7} / 0.55 ^{H7}	18 ^{H7} / 0.71 ^{H7}	18 ^{H7} / 0.71 ^{H7}	18 ^{H7} / 0.71 ^{H7}	18 ^{H7} / 0.71 ^{H7}
Servo motor type	MELDAS	HF-75T	HF-104T	HF-104T	HF-104T / HF-154T	HF-204S
	FANUC	α2 i	α4 i	α4 i	α4 i / α8 i	α12 i
	SIEMENS	1FK7042	1FK7060	1FK7060	1FK7060 / 1FK7063	1FK7083
	HEIDENHAIN	QSY96G	QSY116C	QSY116C	QSY116C / QSY116E	QSY155B / QSY155C
Gear Ratio		1:60	1:90	1:90	1:180/1:90	1:180/1:90
Min. Indexing Unit degree (degree)		0.001°	0.001°	0.001°	0.001°	0.001°
Max. R.P.M. (rpm) (motor : 2000 / rpm)		33.3	22.2	22.2	11.1/22.2	11.1/22.2
Pneu. clamp force (kg•m) (P:5kg / cm ²)		12	25	25	47	71
Hydro. clamp force (kg•m) (P:20kg / cm ²)		24	50	50	94	142
Indexing Accuracy Class (sec.)		30" High Accuracy Rotary Table Refer to P59 chart 2				
Repeatability (sec.)	Unidirectional	4"	4"	4"	4"	4"
	Bidirectional	8"	8"	8"	8"	8"
Max. Machining Force (kg•m)		12	23	23	45	78
N.W. (kgs)		28	70	84	124	210
Max. Load	Vertical	W=35 kg	W=100 kg	W=125 kg	W=150 kg	W=175 kg
	Horizontal	W=75 kg	W=200 kg	W=250 kg	W=300 kg	W=350 kg
Max. Radial Load		F=800 kg	F=1000 kg	F=1100 kg	F=1450 kg	F=2500 kg
		FxL=8 kg•m	FxL=50 kg•m	FxL=50 kg•m	FxL=94 kg•m	FxL=142 kg•m
		FxL=18 kg•m	FxL=78 kg•m	FxL=100 kg•m	FxL=180 kg•m	FxL=200 kg•m

- * GSA remains the right of modification. All specifications can be modified according to customers' requirement.
- Up & backside cable outlet is available, slant motor cover also available
 - Standard accessory : eye bolts, clamping blocks
 - ⊙ Adapting Tailstock → Refer to P : 34-36
 - ⊙ To match AC-/DC-/Stepping-Controller → Refer to P : 53-55
 - ⊙ Optional accessories → Refer to P : 58

● Outlet of wire box could be decided by customers order

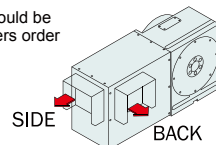

CNC-120R

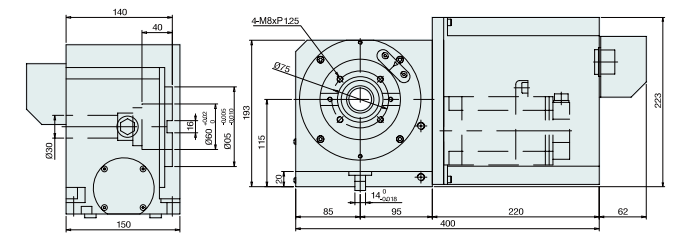

CNC-170R

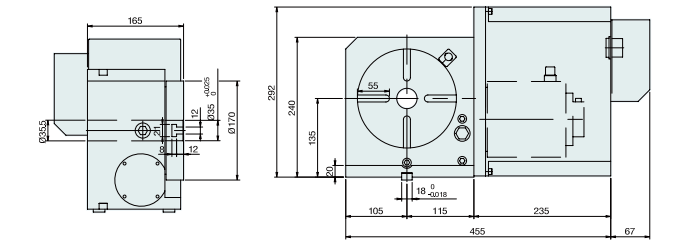

CNC-200R

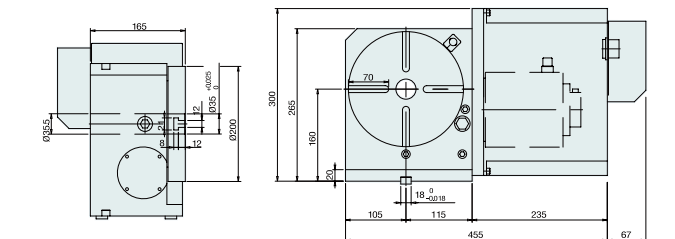

CNC-250R

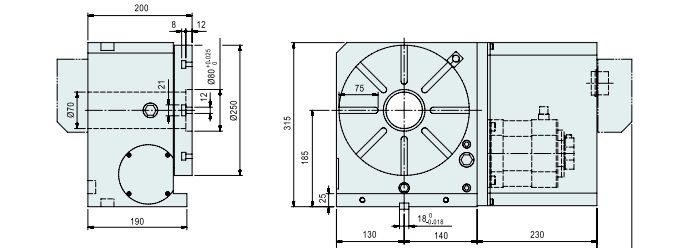

CNC-320R

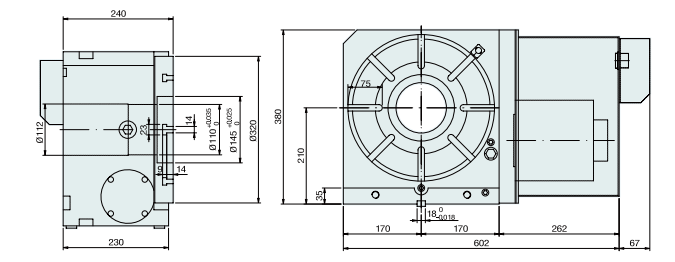

NOTE : Difference motor becomes difference length of motor cover

Accuracy Standards		Unit:mm					
ITEM	Table top flatness	Parallelism of table top and frame bottom	Runout of table spindle center	Perpendicularity of table top to frame bottom	Table top runout	Perpendicularity of table top to frame bottom guide block	Parallelism of center line between headstock & tailstock to frame bottom guide block
MODEL							
CNC-120R	0.01	0.01	0.015	0.012	0.01	0.02	0.02
CNC-170R	0.01	0.01	0.01	0.02	0.015	0.02	0.02
CNC-200R	0.01	0.01	0.01	0.02	0.015	0.02	0.02
CNC-250R	0.01	0.01	0.01	0.02	0.015	0.02	0.02
CNC-320R	0.01	0.01	0.01	0.02	0.015	0.02	0.02



- ⊙ A combination of high precision bronze / nickel worm wheel and case hardened steel worm screw ensures long term indexing accuracy.
- ⊙ Dual lead worm wheel/worm shaft which allow easy backlash adjustment.
- ⊙ Double bearing design suitable for heavy cutting.
- ⊙ One piece of faceplate and spindle design which offer rigid construction.
- ⊙ Low Gear ratio design (90:1) which offer high speed feed rate.
- ⊙ **Large thru hole design** which allow large work piece going thru spindle.

MODEL NO : **CNC-400 R/L**

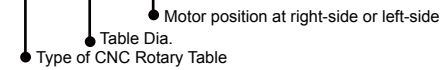

ITEM / MODEL		CNC-400R	CNC-500R	CNC-630R	CNC-800R
Table Dia (mm/inch)		400 / 15.75	500 / 19.69	630 / 24.8	800 / 31.5
Center Height in Vertical (mm / inch)		250 / 9.84	310 / 12.20	400 / 15.75	480 / 18.90
Table Height in Horizontal (mm / inch)		250 / 9.84	290 / 11.42	320 / 12.60	340 / 13.39
Over all Height in Vertical Without Motor Cover (mm / inch)		460 / 18.11	570 / 22.44	725 / 28.54	880 / 34.65
Thru-Hole Dia (mm / inch)		150 ^{H7} / 5.9 ^{H7}	180 ^{H7} / 7.09 ^{H7}	254 ^{H7} / 10 ^{H7}	254 ^{H7} / 10 ^{H7}
Width of T-slot (mm / inch)		14 ^{H7} / 0.55 ^{H7}	18 ^{H7} / 0.71 ^{H7}	18 ^{H7} / 0.71 ^{H7}	20 ^{H7} / 0.79 ^{H7}
Width of Guide Block (mm / inch)		18 ^{H7} / 0.71 ^{H7}	18 ^{H7} / 0.71 ^{H7}	18 ^{H7} / 0.71 ^{H7}	22 ^{H7} / 0.87 ^{H7}
Servo motor type	MELDAS	HF-204S	HF-204S / HF-354S	HF-354S	HF-354S
	FANUC	α12 i	α12 i / α22 i	α22 i	α22 i
	SIEMENS	1FK7083	1FK7083 / 1FK7101	1FK7101	1FK7101
	HEIDENHAIN	QSY155C	QSY155F	QSY190C	QSY190C
Gear Ratio		1:90	1:120	1:180	1:180
Min. Indexing (degree)		0.001°	0.001°	0.001°	0.001°
Max. R.P.M. (rpm) (motor : 2000 / rpm)		22.2	16.7	11.1	11.1
Pneu. clamp force (kg·m) (P:5kg / cm ²)		92	160	350	430
Hydro. clamp force (kg·m) (P:20kg / cm ²)		184	380	700	1050
Indexing Accuracy Class (sec.)		A	15"	A	15"
High Accuracy Rotary Table Refer to P59 chart 2					
Repeatability (sec.)	Unidirectional	4"	4"	4"	4"
	Bidirectional	8"	8"	8"	8"
Max. Machining Force (kg·m)		160	230	320	350
N.W. (kgs)		280	480	860	1200
Max. Load	Vertical	W=300 kg	W=350 kg	W=400 kg	W=600 kg
	Horizontal	W=500 kg	W=600 kg	W=1000 kg	W=1500 kg
Max. Radial Load		F=3500 kg	F=4000 kg	F=5000 kg	F=6000 kg
		FxL=184 kg·m	FxL=380 kg·m	FxL=700 kg·m	FxL=1050 kg·m
		FxL=250 kg·m	FxL=350 kg·m	FxL=800 kg·m	FxL=1000 kg·m

* GSA remains the right of modification. All specifications can be modified according to customers' requirement.

- Up & backside cable outlet is available, slant motor cover also available
- Standard accessory : eye bolts, clamping blocks
- ⊙ Adapting Tailstock → Refer to P : 34-36
- ⊙ To match AC-/DC-/Stepping-Controller → Refer to P : 53-55
- ⊙ Optional accessories → Refer to P : 58

CNC-400R

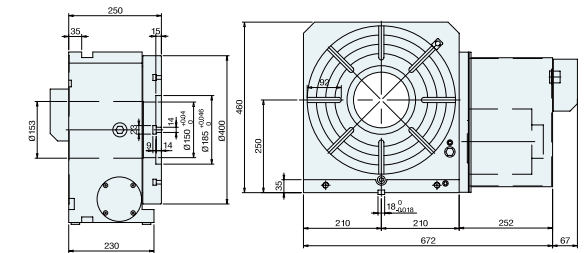

CNC-500R

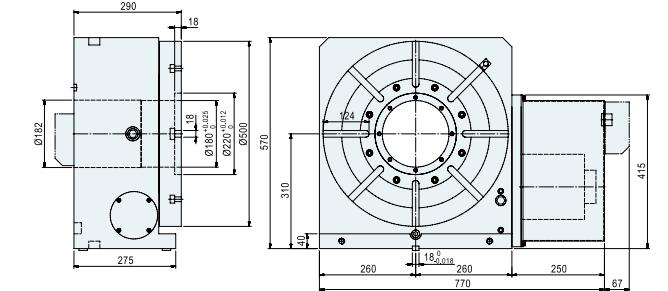

CNC-630R

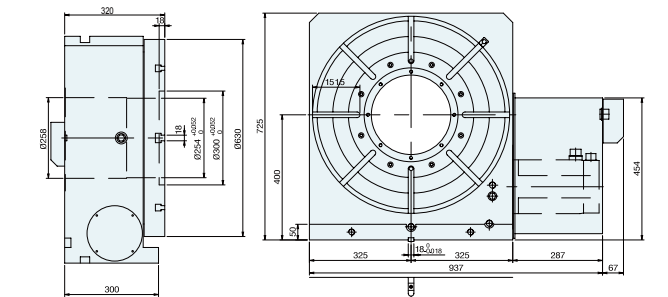

CNC-800R

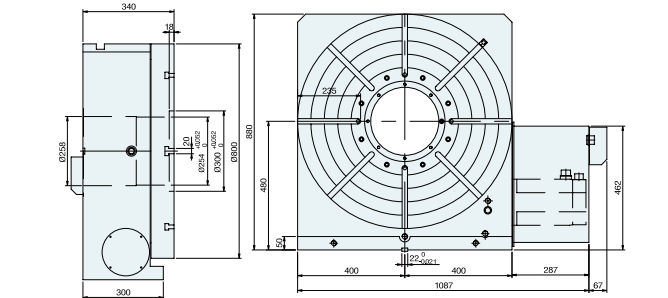

Accuracy Standards								Unit:mm
ITEM	Table top flatness	Parallelism of table top and frame bottom	Runout of table spindle center	Perpendicularity of table top to frame bottom	Table top runout	Perpendicularity of table top to frame bottom guide block	Parallelism of center line between headstock & tailstock to frame bottom guide block	
CNC-400R	0.015	0.015	0.01	0.02	0.015	0.02	0.02	
CNC-500R	0.015	0.015	0.01	0.02	0.015	0.02	0.02	
CNC-630R	0.025	0.025	0.01	0.025	0.02	0.02	0.02	
CNC-800R	0.025	0.025	0.01	0.025	0.02	0.02	0.02	

CNC

CNCB

CNCT
/
CNCMT

NCF

Tailstock

Large
Size
Table

GCT

PT

APCR
/
APCI

Controller

Coupling

Accessories

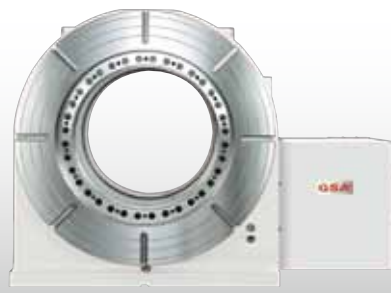

- ◎ A combination of high precision bronze / nickel worm wheel and case hardened steel worm screw ensures long term indexing accuracy.
- ◎ Dual lead worm wheel / worm shaft which allowable easy backlash adjustment.
- ◎ Mega thru hole design which allowable large work piece going thru spindle.

ITEM / MODEL		CNCB-800R	CNCB-800RT
Table Diameter (mm/inch)		800 / 31.5	
Center Height in Vertical (mm/inch)		480 / 18.90	
Table Height in Horizontal (mm/inch)		375 / 14.77	
Over All Height in Vertical Without Motor Cover (mm/inch)		895 / 35.24	
Thru-Hole Diameter (mm)		450 ^{H7} / 17.72 ^{H7}	
Width of T-slot (mm)		20 ^{H7} / 0.79 ^{H7}	
Width of Guide Block (mm)		22 ^{H7} / 0.87 ^{H7}	
Servo Motor Type	MELDAS	HF-354S	
	FANUC	α22 i	
	SIEMENS	1FK7101	
	HEIDENHAIN	QSY190C	
Gear Ratio		1:180	
Min. Increment (degree)		0.001°	
Max. R.P.M. (rpm)(motor: 200 / rpm)		11.1	
Hydro. Clamp Force (kg·m)(P:20kg / cm ²)		1600	
Indexing Accuracy Class (sec.)		A 15"	
Repeatability (sec.)	Unidirectional	4"	
	Bidirectional	8"	
Max. Machining Force (kg·m)		350	
N. W. (kgs)		1060	
Max. Load	Vertical	W=1500kg	
	Horizontal	w=3000kg	
Max. Radial Load		F=5000kg	
		FxL=1600kg·m	
		FxL=1600kg·m	
		FxL=1600kg·m	

※ GSA remains the right of modification. All specifications can be modified according to customers' requirement.

CNCB-800R

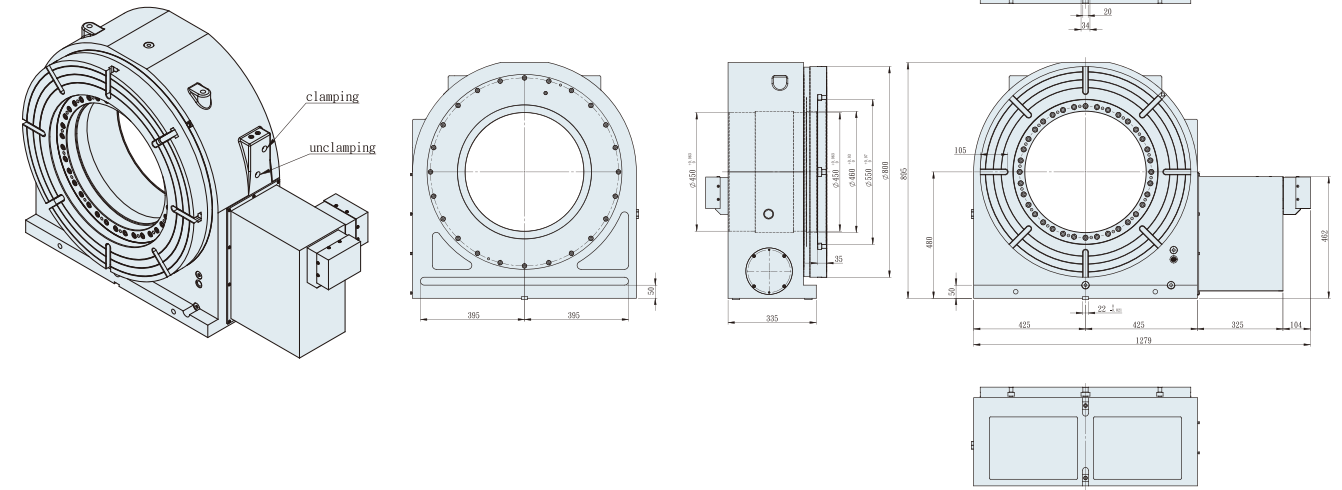

CNCB-800RT

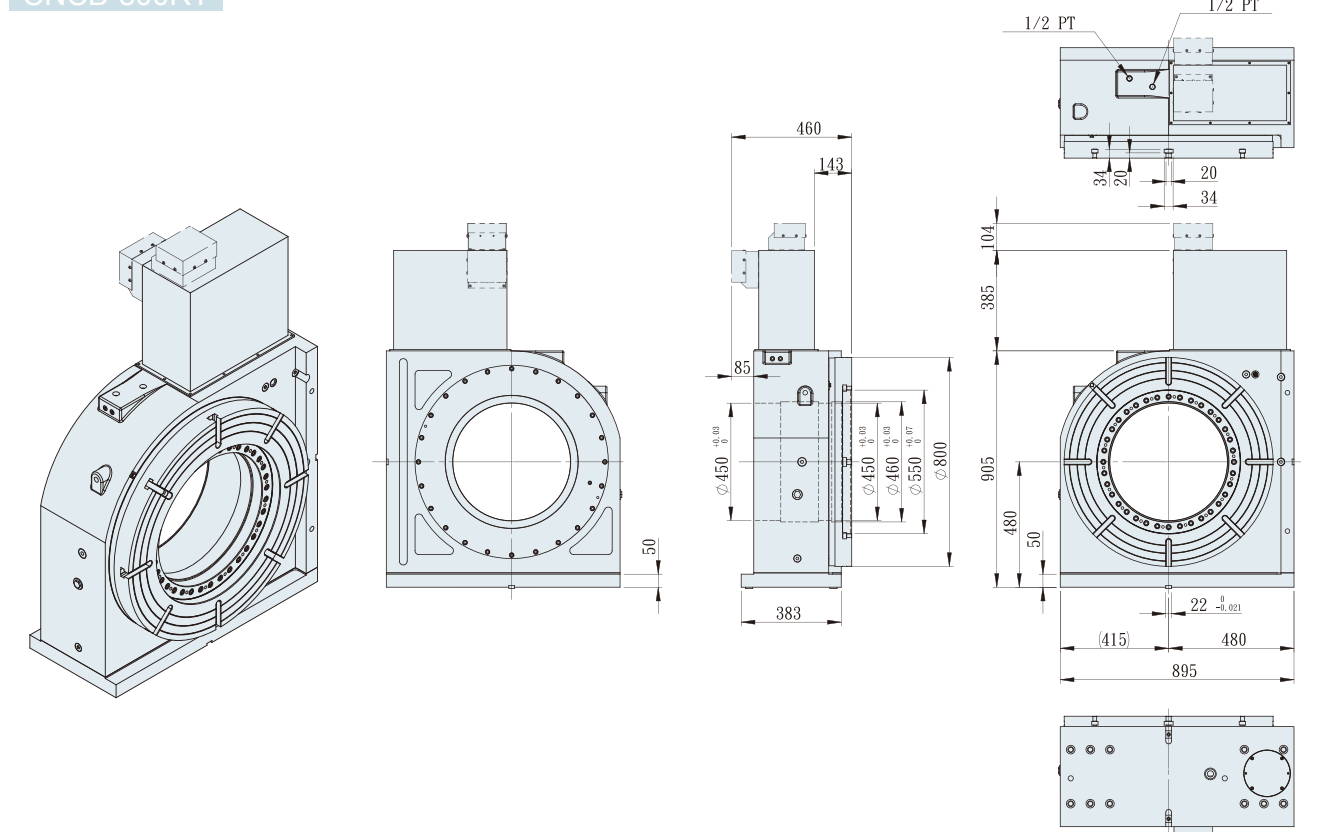

CNC

CNCB

CNCT
/
CNCMT

NCF

Tailstock

Large
Size
Table

GCT

PT

APCR
/
APCI

Controller

Coupling

Accessories

Accuracy Standards							Unit:mm
ITEM	Table top flatness	Parallelism of table top and frame bottom	Runout of table spindle center	Perpendicularity of table top to frame bottom	Table top runout	Perpendicularity of table top to frame bottom guide block	Parallelism of center line between headstock & tailstock to frame bottom guide block
CNCB-800R	0.015	0.015	0.01	0.02	0.015	0.02	0.02
CNCB-800RT	0.015	0.015	0.01	0.02	0.015	0.02	0.02

CNC

CNCB

CNCT / CNCMT

NCF

Tailstock

Large Size Table

GCT

PT

APCR / APCI

Controller

Coupling

Accessories



- ⊙ Back-Mounted Motor, avoid the interference with M/C splash guard.
- ⊙ Suitable for small-size of CNC Machining / Tapping-Center.

※This model can not be installed horizontal position.

MODEL NO : CNC-170 RB

- Table Dia.
- Back-Mounted Motor
- Type of CNC Rotary Table

ITEM / MODEL		CNC-120RB	CNC-170RB	CNC-200RB	CNC-250RB				
Table Dia (mm/inch)		120 / 4.72	170 / 6.69	200 / 7.87	250 / 9.84				
Center Height in Vertical (mm / inch)		115 / 4.53	135 / 5.31	160 / 6.3	185 / 7.28				
Over all Height in Vertical (mm / inch)		250 / 9.84	300 / 11.81	325 / 12.5	365 / 14.37				
Thru-Hole Dia (mm / inch)		30 ^{H7} / 1.18 ^{H7}	35 ^{H7} / 1.38 ^{H7}	35 ^{H7} / 1.38 ^{H7}	70 ^{H7} / 2.75 ^{H7}				
Width of T-slot (mm / inch)		10 ^{H7} / 0.39 ^{H7}	12 ^{H7} / 0.47 ^{H7}	12 ^{H7} / 0.47 ^{H7}	12 ^{H7} / 0.47 ^{H7}				
Width of Guide Block (mm / inch)		14 ^{H7} / 0.55 ^{H7}	18 ^{H7} / 0.71 ^{H7}	18 ^{H7} / 0.71 ^{H7}	18 ^{H7} / 0.71 ^{H7}				
Servo motor type	MELDAS	HF-75T	HF-104T	HF-104T	HF-104T				
	FANUC	α2 i	α4 i	α4 i	α4 i				
	SIEMENS	1FK7042	1FK7060	1FK7060	1FK7060				
	HEIDENHAIN	QSY96G	QSY116C	QSY116C	QSY116C				
Gear Ratio		1:60	1:90	1:90	1:90				
Min. Indexing (degree)		0.001°	0.001°	0.001°	0.001°				
Max. R.P.M. (rpm) (motor : 2000 / rpm)		33.3	22.2	22.2	22.2				
Pneu. clamp force (kg·m) (P:5kg / cm ²)		12	25	25	47				
Hydro. clamp force (kg·m) (P:20kg / cm ²)		24	50	50	94				
Indexing Accuracy Class (sec.)		A	60"	A	20"	A	20"	A	15"
		High Accuracy Rotary Table Refer to P59 chart 2							
Repeatability (sec.)	Unidirectional	4"	4"	4"	4"				
	Bidirectional	8"	8"	8"	8"				
Max. Machining Force (kg·m)		12	23	23	45				
N.W. (kgs)		70	70	84	124				
Max. Load	Vertical	W=35 kg	W=100 kg	W=125 kg	W=150 kg				
	Horizontal	W=75 kg	W=200 kg	W=250 kg	W=300 kg				
Max. Radial Load		F=800 kg	F=1000 kg	F=1100 kg	F=1450 kg				
		FxL=8 kg·m	FxL=50 kg·m	FxL=50 kg·m	FxL=94 kg·m				
		FxL=18 kg·m	FxL=78 kg·m	FxL=100 kg·m	FxL=180 kg·m				

※ GSA remains the right of modification. All specifications can be modified according to customers' requirement.

- Up & backside cable outlet is available, slant motor cover also available
- Standard accessory : eye bolts, clamping blocks
- ⊙ Adapting Tailstock→ Refer to P : 34-36
- ⊙ To match AC-/DC-/Stepping-Controller→ Refer to P : 53-55
- ⊙ Optional accessories→ Refer to P : 58

CNC

CNCB

CNCT / CNCMT

NCF

Tailstock

Large Size Table

GCT

PT

APCR / APCI

Controller

Coupling

Accessories

CNC-170RB

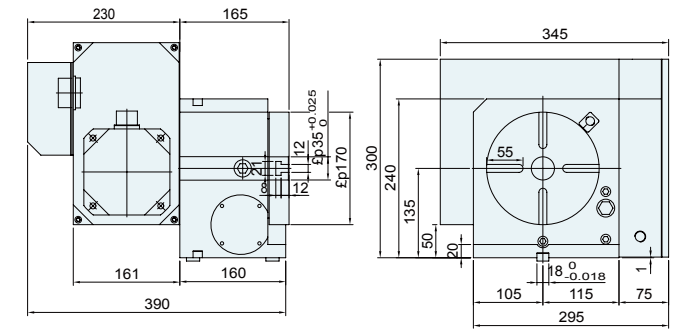

CNC-200RB

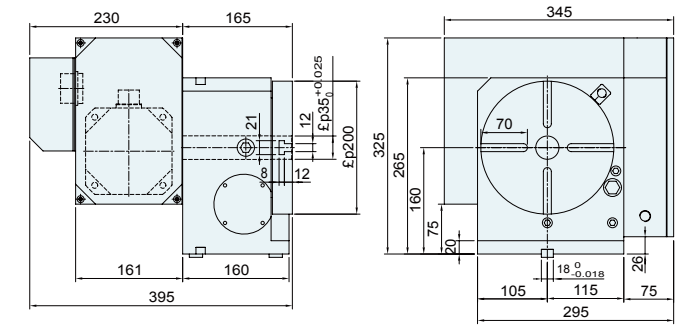

CNC-250RB

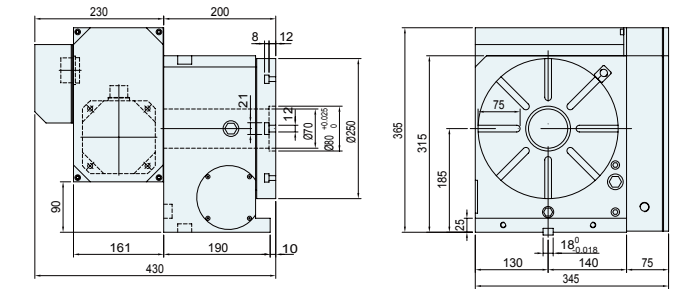

Accuracy Standards							Unit:mm
ITEM	Table top flatness	Parallelism of table top and frame bottom	Runout of table spindle center	Perpendicularity of table top to frame bottom	Table top runout	Perpendicularity of table top to frame bottom guide block	Parallelism of center line between headstock & tailstock to frame bottom guide block
CNC-120RB	0.01	0.01	0.01	0.02	0.015	0.02	0.02
CNC-170RB	0.01	0.01	0.01	0.02	0.015	0.02	0.02
CNC-200RB	0.01	0.01	0.01	0.02	0.015	0.02	0.02
CNC-250RB	0.01	0.02	0.01	0.02	0.015	0.02	0.02

CNC

CNC-170R-2W

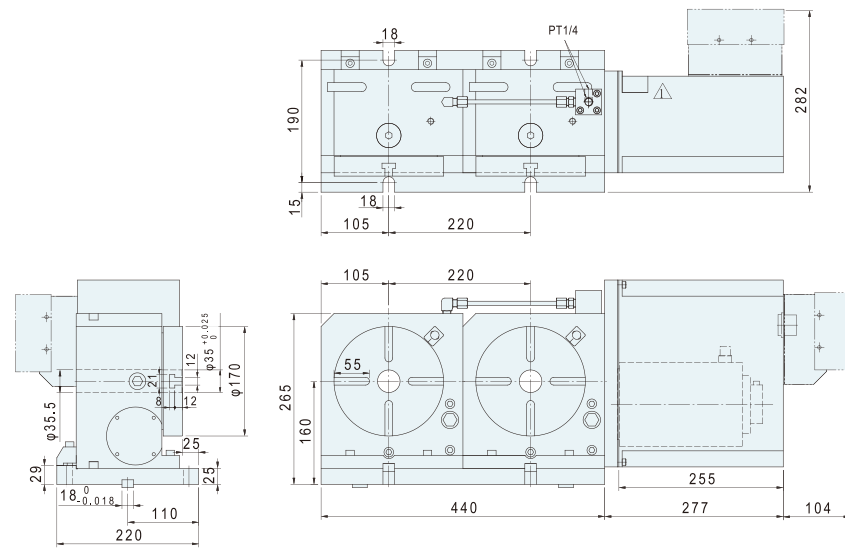

CNCB

CNCT / CNCMT

NCF

CNC-200R-2W

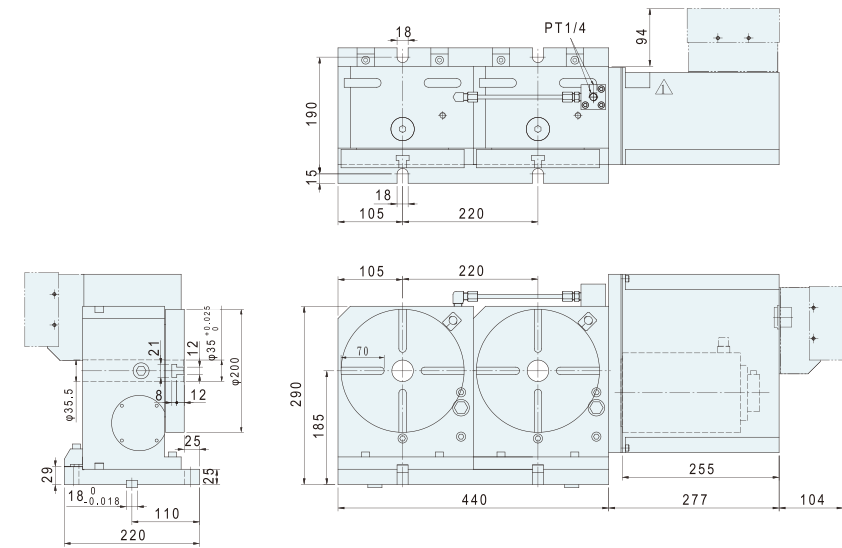

CNC

CNCB

CNCT / CNCMT

NCF

Tailstock

CNC-170R-3W

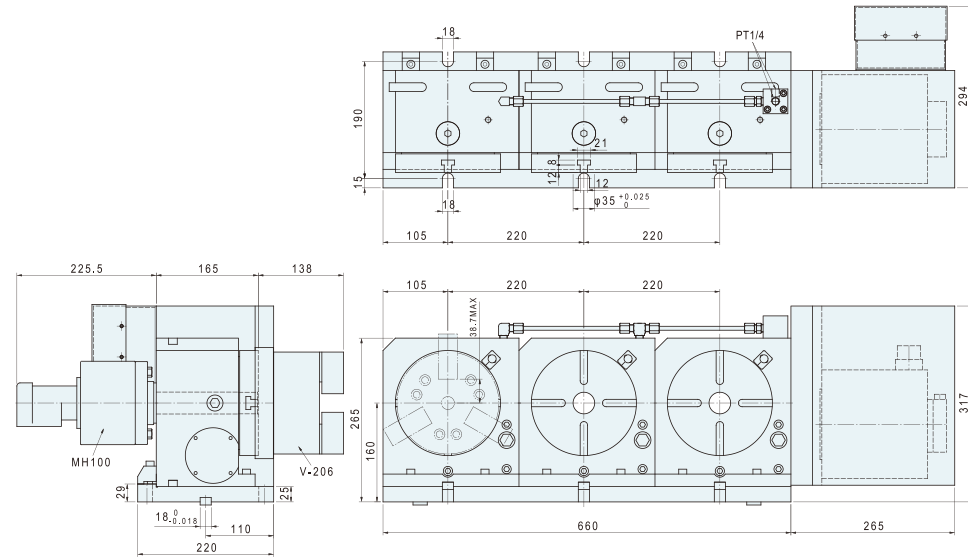

Large Size Table

GCT

PT

CNC-200R-3W

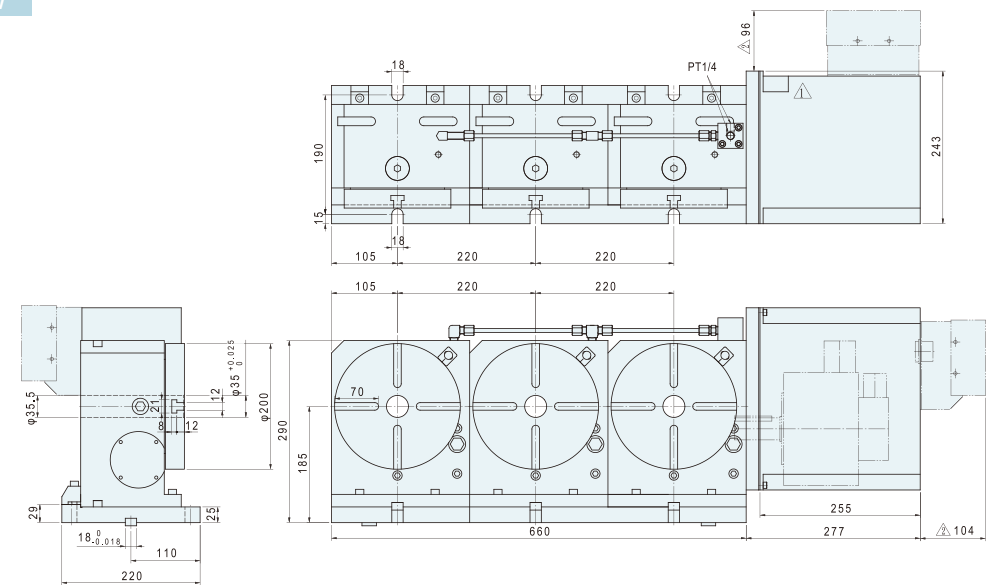

Tailstock

Large Size Table

GCT

PT

APCR / APCI

CNC-170R-4W

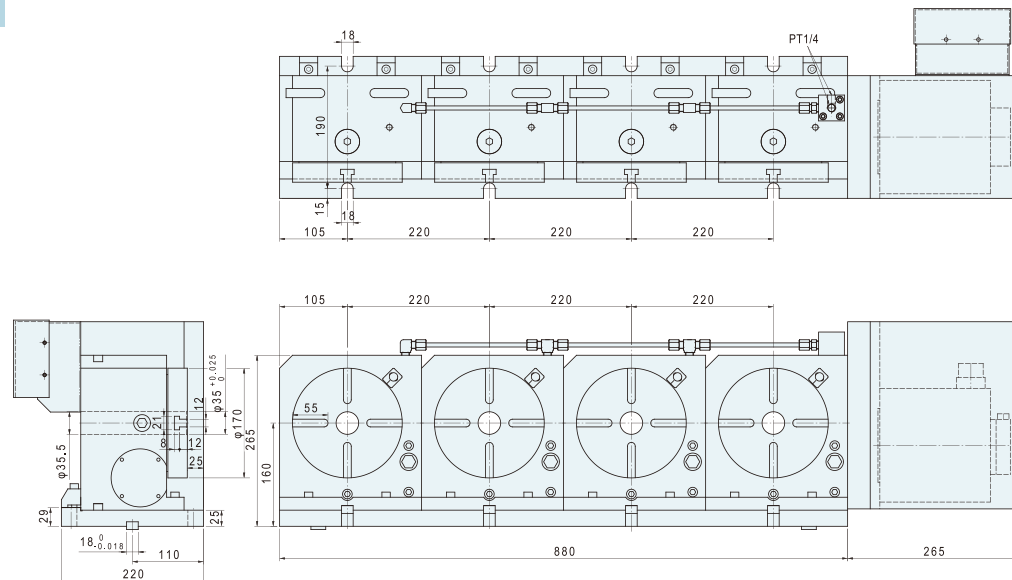

CNC-200R-4W

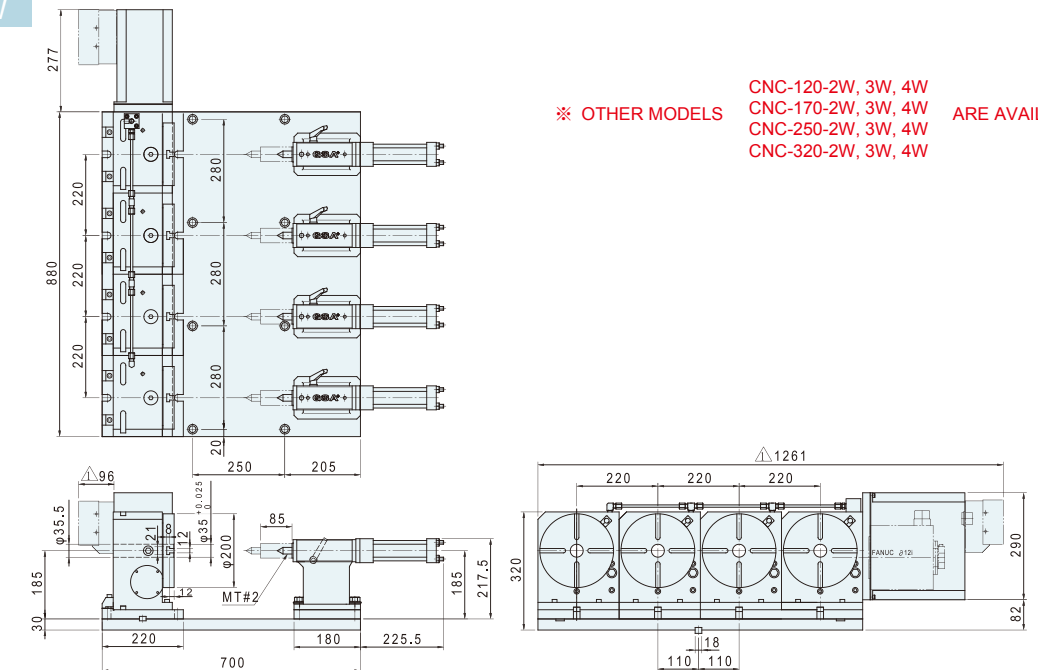

※ OTHER MODELS ARE AVAILABLE
 CNC-120-2W, 3W, 4W
 CNC-170-2W, 3W, 4W
 CNC-250-2W, 3W, 4W
 CNC-320-2W, 3W, 4W

Controller

Coupling

Accessories

Controller

Coupling

Accessories

CNC

CNCB

CNCT / CNCMT

NCF

Tailstock

Large Size Table

GCT

PT

APCR / APCI

Controller

Coupling

Accessories



- ⊙ Easy Installation Easy Operation.
- ⊙ Compact Design Wide Machine Range.
- ⊙ Even Approx. One Meter Table M/C Could be Installed.
- ⊙ To match 5 axes M/C for continuing machining, the tilting axis could be connected the M-code by using our single axis AC/DC/Stepping servo controller.

MODEL NO : CNCT-250

- Table Dia.
- Type of CNC Tilting Rotary Table

ITEM / MODEL		CNCT-100	CNCT-200	CNCT-250	CNCT-320				
Table Dia (mm)		120	200	250	320				
Table center Height in Vertical (mm)		150	195	225	255				
Over all Height in Vertical (mm)		235	360	355	425				
Thru-Hole Dia (mm)		30 ^{H7}	35 ^{H7}	70 ^{H7}	110 ^{H7}				
Width of T-slot (mm)		10 ^{H7}	12 ^{H7}	12 ^{H7}	14 ^{H7}				
Width of Guide Block (mm)		14 ^{H7}	18 ^{H7}	18 ^{H7}	18 ^{H7}				
Servo motor type		Rotating	Tilting	Rotating	Tilting	Rotating	Tilting	Rotating	Tilting
	MELDAS	HF-75T	HF-75T	HF-104T	HF-154T	HF-104T	HF-154T	HF-154T	HF-204S
	FANUC	α2 i	α2 i	α4 i	α8 i	α4 i	α8 i	α8 i	α12 i
	SIEMENS	1FK7042	1FK7042	1FK7060	1FK7063	1FK7060	1FK7063	1FK7063	1FK7083
	HEIDENHAIN	QSY96G	QSY96G	QSY116C	QSY116E	QSY116C	QSY116E	QSY116E	QSY155B
Gear Ratio		1:72	1:120	1:90	1:180	1:90	1:180	1:180	1:180
Min. Increment(degree)		0.001°	0.001°	0.001°	0.001°	0.001°	0.001°	0.001°	0.001°
Max. R.P.M. (rpm) (motor : 2000 / rpm)		27.8	16.7	22.2	11.1	22.2	11.1	11.1	11.1
Tilting degree		-20°~120°		-110°~110°		-110°~110°		-110°~110°	
Rotation axis	Pneu. clamp force(kg·m)(P:5kg / cm ²)	12	25	50	71				
	Hydro. clamp force(kg·m)(P:20kg / cm ²)	24	50	100	142				
	Indexing Accuracy (sec.)	30"	20"	15"	15"				
Tilting axis	Pneumatic/Hydraulic clamping force(kg·m)	12/24	25/50	50/100	71/142				
	Indexing Accuracy (sec.)	60"	50"	30"	30"				
N.W (kgs)		105	240	280	450				
Max. Load	Vertical	W=20 kg	W=50 kg	W=60 kg	W=100 kg				
	Horizontal	W=35 kg	W=100 kg	W=100 kg	W=200 kg				
Max. Radial Load		F=400 kg	F=500 kg	F=1200 kg	F=1500 kg				
		FxL=24 kg·m	FxL=50 kg·m	FxL=100 kg·m	FxL=142 kg·m				
		FxL=30 kg·m	FxL=102 kg·m	FxL=120 kg·m	FxL=200 kg·m				
Max. Working Inertia	$J = \frac{WD^2}{(8 \times 980)}$	0.87kg·cm·sec ²	6kg·cm·sec ²	8kg·cm·sec ²	26kg·cm·sec ²				

※ GSA remains the right of modification. All specifications can be modified according to customers' requirement.

- Standard accessory : eye bolts, clamping blocks
- Could be increased tilting angle ±180°
- ⊙ Adapting Tailstock→ Refer to P : 34-36
- ⊙ To match AC/DC/Stepping-Controller→ Refer to P : 53-55

CNCT-100

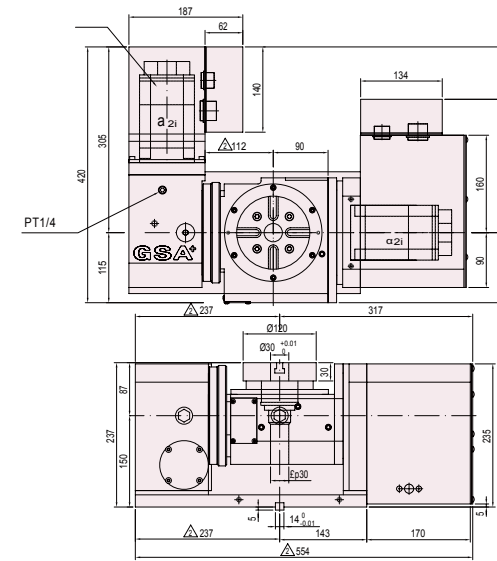

CNCT-200

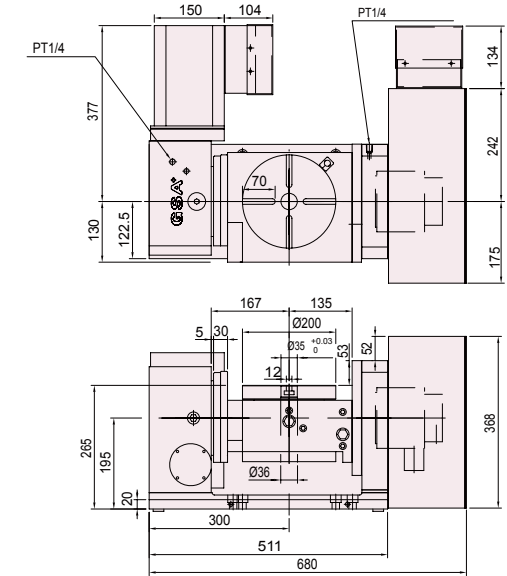

CNCT-250A

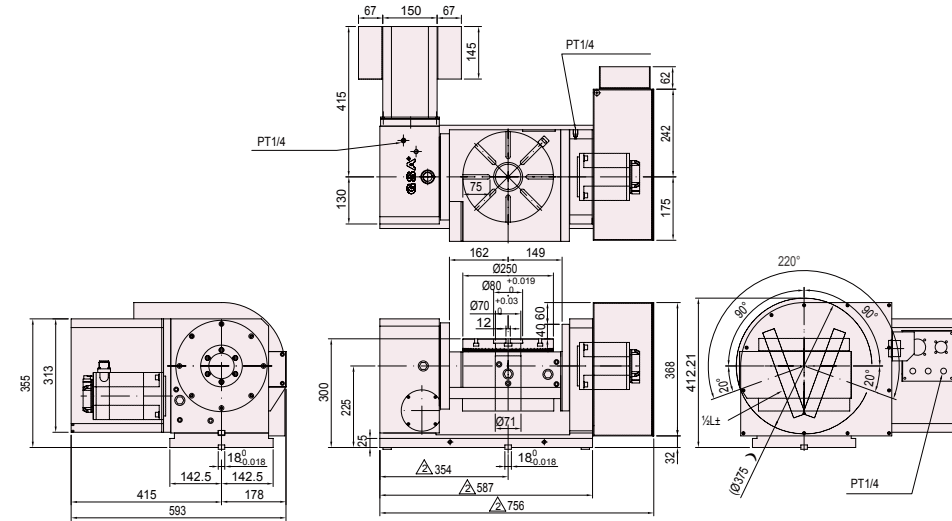

CNCT-320

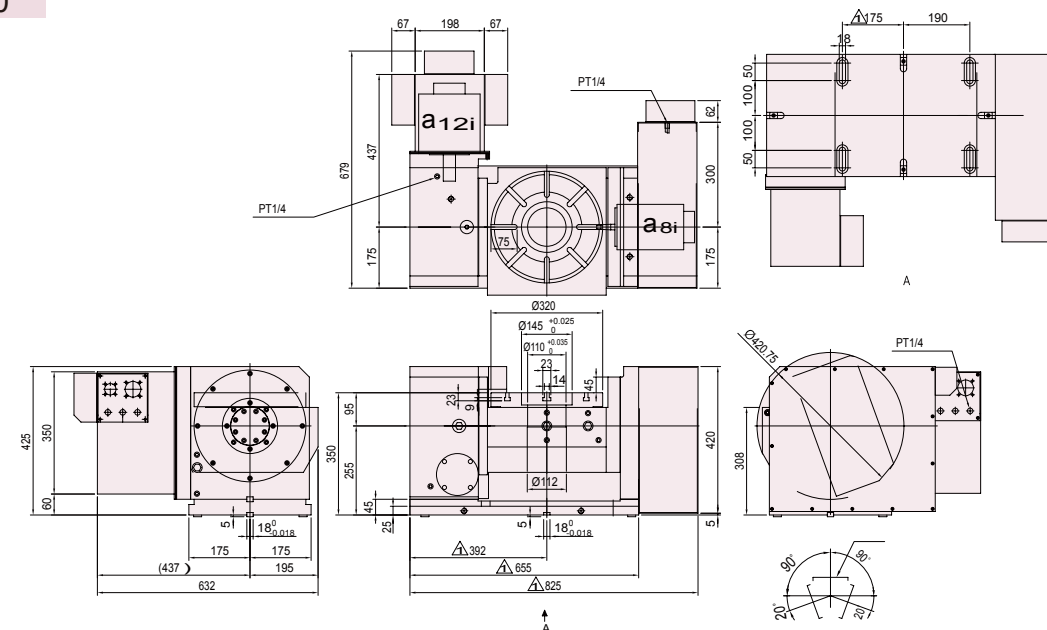

CNC

CNCB

CNCT / CNCMT

NCF

Tailstock

Large Size Table

GCT

PT

APCR / APCI

Controller

Coupling

Accessories

CNC

CNCB

CNCT / CNCMT

NCF

Tailstock

Large Size Table

GCT

PT

APCR / APCI

Controller

Coupling

Accessories

CNC

CNCB

CNCT / CNCMT

NCF

Tailstock

Large Size Table

GCT

PT

APCR / APCI

Controller

Coupling

Accessories



- ⊙ Dual-Lead worm wheel and worm shaft design with wear-resisting material suitable for 5 axes simultaneous machining.
- ⊙ Low center height profile design with wide range machining space.
- ⊙ Optional balance pistons provides heavy cutting application and long-term using.

MODEL NO : **CNCT-450**

● Table Dia.
● Type of CNC Tilting Rotary Table

ITEM / MODEL		CNCT-320RS		CNCT-450		CNCT-630		CNCT-800	
Table Dia (mm)		320		450		630		800	
Table center Height in Vertical (mm)		375		440		580		650	
Over all Height in Vertical (mm)		675		650		905		1050	
Thru-Hole Dia (mm)		145 ^{H7}		150 ^{H7}		254 ^{H7}		254 ^{H7}	
Width of T-slot (mm)		14 ^{H7}		14 ^{H7}		18 ^{H7}		20 ^{H7}	
Width of Guide Block (mm)		18 ^{H7}		18 ^{H7}		22 ^{H7}		22 ^{H7}	
Servo motor type		Rotating	Tilting	Rotating	Tilting	Rotating	Tilting	Rotating	Tilting
	MELDAS	HF-154T	HF-354S	HF-204S	HF-354S	HF-354S	HF-354S	HF-354S	HF-453S
	FANUC	α8 i	α22 i	α12 i	α22 i	α22 i	α22 i	α22 i	α30 i
	SIEMENS	1FK7063	1FK7101	1FK7083	1FK7101	1FK7101	1FK7101	1FK7101	1FK7103
	HEIDENHAIN	QSY116E	QSY155F	QSY155C	QSY155F	QSY190C	QSY190C	QSY190C	QSY190D
Gear Ratio		1:180		1:180		1:180		1:180	
Min. Increment(degree)		0.001°		0.001°		0.001°		0.001°	
Max. R.P.M. (rpm) (motor : 2000 / rpm)		11.1		11.1		22.2		11.1	
Tilting degree		-120°~120°		-120°~120°		-120°~120°		-120°~120°	
Rotation axis	Pneu. clamp force(kg·m)(P:5kg / cm ²)	71		90		350		450	
	Hydro. clamp force(kg·m)(P:20kg / cm ²)	142		180		450		450	
	Indexing Accuracy (sec.)	15"		15"		15"		15"	
	Repeatability (sec.)	4"		4"		4"		4"	
Tilting axis	Pneumatic/Hydraulic clamping force(kg·m)	95/190		120/210		420/800		-/1250	
	Indexing Accuracy (sec.)	30"		30"		30"		30"	
N.W (kgs)		1050		1160		2650		4850	
Max. Load	Vertical	W=100 kg		W=150 kg		W=300 kg		W=600 kg	
	Horizontal	W=200 kg		W=300 kg		W=500 kg		W=1000 kg	
Max. Radial Load		F=1500 kg		F=1880 kg		F=2080 kg		F=2600 kg	
		FxL=190 kg·m		FxL=210 kg·m		FxL=800 kg·m		FxL=1250 kg·m	
		FxL=200 kg·m		FxL=280 kg·m		FxL=390 kg·m		FxL=460 kg·m	
		FxL=200 kg·m		FxL=280 kg·m		FxL=390 kg·m		FxL=460 kg·m	
Max. Working Inertia	$J = \frac{WD^2}{(8 \times 980)}$	26kg·cm·sec ²		100kg·cm·sec ²		360kg·cm·sec ²		1000kg·cm·sec ²	

※ GSA remains the right of modification. All specifications can be modified according to customers' requirement.

- Standard accessory : eye bolts, clamping blocks
- Could be increased tilting angle ±180°

- ⊙ Adapting Tailstock→ Refer to P : 34-36
- ⊙ To match AC/DC-/Stepping-Controller→ Refer to P : 53-55

CNCT-320RS

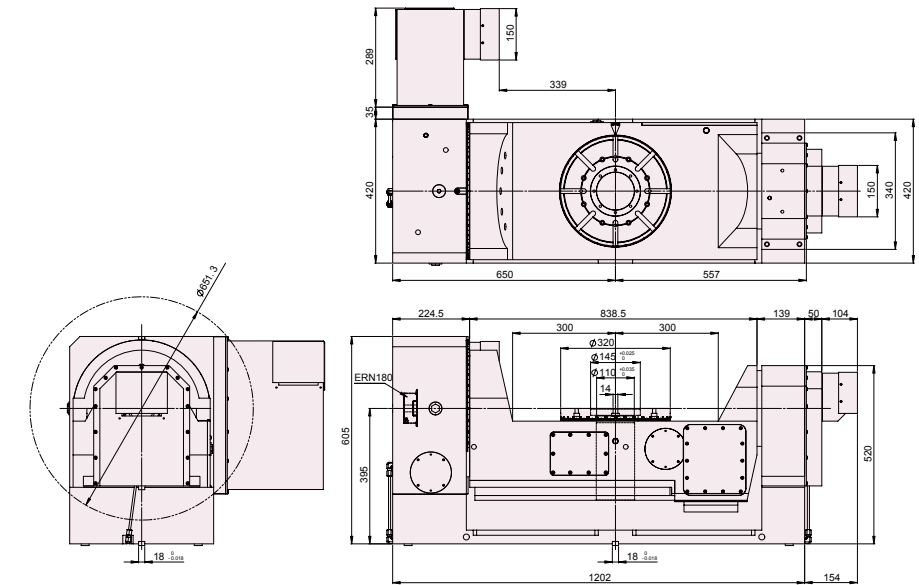

CNCT-450

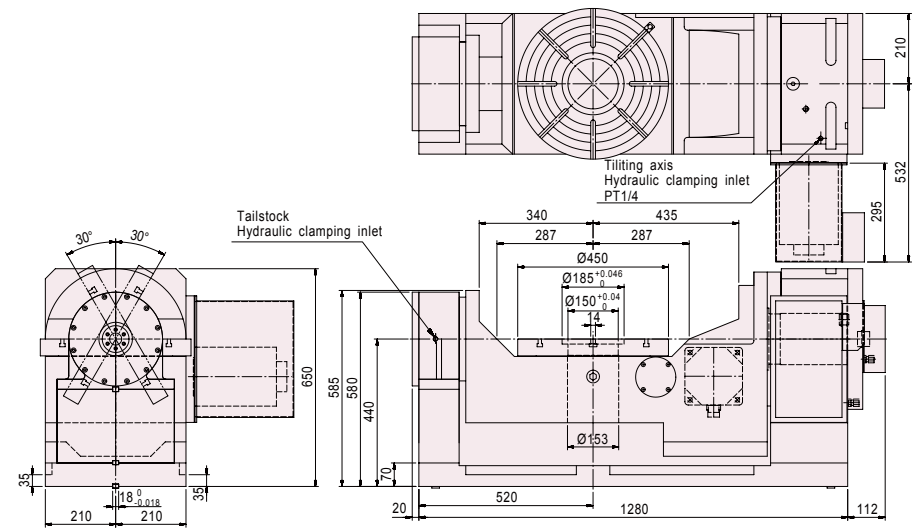

CNCT-630

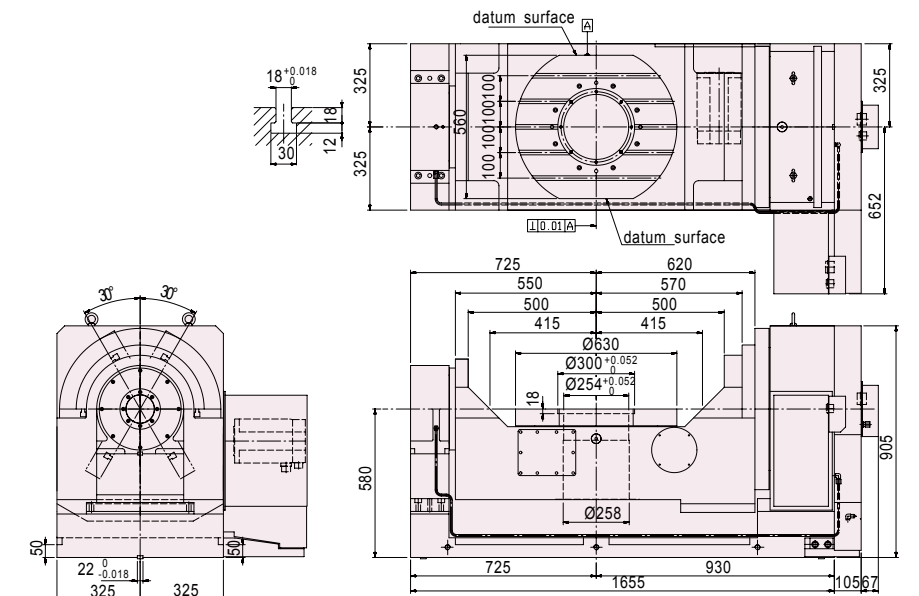

CNC

CNCB

CNCT / CNCMT

NCF

Tailstock

Large Size Table

GCT

PT

APCR / APCI

Controller

Coupling

Accessories

CNCT-800

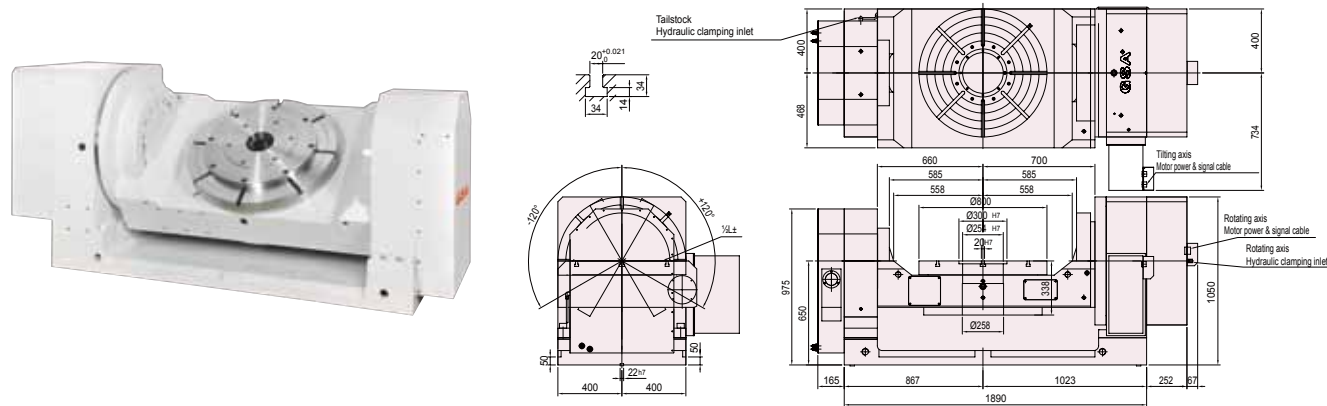

Accuracy Standards								Unit:mm		
ITEM	Table top flatness	Parallelism of table top and frame bottom	Runout of table spindle center	Table top runout	Parallelism of tilting axis center line and frame bottom	Parallelism of table top to frame bottom guide	An encoder measuring instrument should be used for indexing accuracy measurements (Rotating)	An encoder measuring instrument should be used for indexing accuracy measurements (Tilting)		
CNCT-100	0.01	0.02	0.01	0.015	0.02	0.02	30"	60"		
CNCT-200	0.01	0.02	0.01	0.015	0.02	0.02	25"	50"		
CNCT-250	0.01	0.02	0.01	0.015	0.02	0.02	15"	50"		
CNCT-320	0.01	0.02	0.01	0.015	0.02	0.02	15"	30"		
CNCT-320RS	0.01	0.02	0.01	0.015	0.02	0.02	15"	30"		
CNCT-450	0.01	0.02	0.01	0.015	0.02	0.02	15"	30"		
CNCT-630	0.01	0.02	0.01	0.015	0.02	0.02	15"	30"		
CNCT-800	0.01	0.02	0.01	0.015	0.02	0.02	15"	30"		

HOW to Retrofit CNCT with M/C & Controller

M/C Preparation	Status of M/C	Completed package for CNCT table							FUNCTION
			CNCT-100	CNCT-200	CNCT-250	CNCT-320	CNCT-450	CNCT-630	
Standard 3 axes	CNC machine equipped with 3 axes (X, Y, Z) without additional axis	Rotating	M-Mate A	M-Mate A	M-Mate A	M-Mate B	M-Mate B	M-Mate B	The rotating and tilting axes only for positioning machining purpose and cost efficiency
		Tilting	M-Mate A	M-Mate A	M-Mate B	M-Mate B	M-Mate C	M-Mate C	
Addition 4th axis	CNC machine equipped with an additional 4th axis (X, Z, A)	Rotating	A axis	A axis	A axis	A axis	A axis	A axis	Tilting axis prepared for positioning machining and rotating axis is prepared for continuing machining (X, Y, Z, A)
		Tilting	M-Mate A	M-Mate A	M-Mate B	M-Mate B	M-Mate C	M-Mate C	
Addition 4th 5th axis	CNC machine equipped with an additional 4th and 5th axes (X, Z, A, B)	Rotating	A axis	A axis	A axis	A axis	A axis	A axis	X · Y · Z · A · B, 5 AXES are prepared for continuing machining
		Tilting	B axis	B axis	B axis	B axis	B axis	B axis	

- Before place your order, please advise us the type of AC-SERVO-MOTOR and SERVO-DRIVE for CNC control system
- Specification of M-Mate controller, refer to P : 55

CNC

CNCB

CNCT / CNCMT

NCF

Tailstock

Large Size Table

GCT

PT

APCR / APCI

Controller

Coupling

Accessories



- Suitable for conventional Milling, Boring and Tapping Machine.
- Suitable to E.D.M. machine, for machining workpieces of wheel-moulding machine of bicycle, motorcycle.
- Manual tilting, Rotating by CNC control.

MODEL NO : CNCMT-320

- CNCMT: Type of Manual Tilting Rotary Table
- TNC: Type of Tilting Dividing Head

ITEM / MODEL	CNCMT-200	CNCMT-250	CNCMT-320	CNCMT-400	CNCMT-500	CNCMT-630							
Table Dia (mm)	ø200	ø250	ø320	ø400	ø500	ø630							
Table Height in Horizontal (mm)	275	280	330	375	400	480							
Center Height in Vertical (mm)	190	210	270	290	330	440							
Over all Height in Vertical (mm)	317	450	595	648	735	940							
Thru-Hole Dia (mm)	30 ^{H7}	70 ^{H7}	110 ^{H7}	150 ^{H7}	180 ^{H7}	254 ^{H7}							
Width of T-slot (mm)	12 ^{H7}	12 ^{H7}	14 ^{H7}	14 ^{H7}	18 ^{H7}	18 ^{H7}							
Width of Guide Block (mm)	18 ^{H7}	18 ^{H7}	18 ^{H7}	18 ^{H7}	18 ^{H7}	18 ^{H7}							
Servo motor type	MELDAS	HF-104T	Rotating	Tilting (Scale)	Rotating	Tilting (Scale)	Rotating	Tilting (Scale)	Rotating	Tilting (Scale)	Rotating	Tilting (Scale)	
	FANUC	α4 i	Manual	Manual	HF-104T	Manual	HF-204S	Manual	HF-204S	Manual	HF-204S	Manual	HF-354S
	SIEMENS	1FK7060			α12 i		α12 i		α12 i		α22 i		
	HEIDENHAIN	QSY116C			1FK7083		1FK7083		1FK7083		1FK7101		
		QSY155C			QSY155C		QSY155F		QSY190C				
Gear Ratio	1:90	-	1:90	-	1:180/1:90	-	1:90	-	1:120	-	1:180	-	
Min. Increment(degree)	0.001°	1°	0.001°	1°	0.001°	1°	0.001°	1°	0.001°	1°	0.001°	1°	
Max. R.P.M. (rpm) (motor : 2000 / rpm)	22.2	-	22.2	-	11.1/22.2	-	22.2	-	16.7	-	11.1	-	
Tilting degree	0°~105°		0°~100°		0°~100°		0°~100°		0°~100°		0°~100°		
Rotation axis	Pneu. clamp force(kg·m)(P:5kg / cm ²)	25	47	71	92	160	350						
	Hydro. clamp force(kg·m)(P:20kg / cm ²)	50	94	142	184	380	700						
	Indexing Accuracy (sec.)	20"	15"	15"	15"	15"	15"						
	Repeatability(sec.)	Unidirectional	4"	4"	4"	4"	4"	4"					
Bidirectional		8"	8"	8"	8"	8"	8"						
N.W (kgs)	135	220	310	380	450	1000							
Max. Load	Vertical	W=40 kg	W=125 kg	W=150 kg	W=300 kg	W=350 kg	W=500 kg						
	Horizontal	W=80 kg	W=300 kg	W=350 kg	W=500 kg	W=600 kg	W=1000 kg						
Max. Radial Load	F	F=600 kg	F=1208 kg	F=1375 kg	F=1585 kg	F=1880 kg	F=2080 kg						
	FxL	FxL=50 kg·m	FxL=94 kg·m	FxL=142 kg·m	FxL=184 kg·m	FxL=380 kg·m	FxL=700 kg·m						
	FxL	FxL=20 kg·m	FxL=72 kg·m	FxL=115 kg·m	FxL=180 kg·m	FxL=245 kg·m	FxL=300 kg·m						

※ GSA remains the right of modification. All specifications can be modified according to customers' requirement.

- Up & backside cable outlet is available, slant motor cover also available
- Standard accessory: eye bolts, clamping blocks
- Adapting Tailstock→ Refer to P : 34-36
- To match AC-/DC-/Stepping-Controller→ Refer to P : 53-55

CNCMT-200

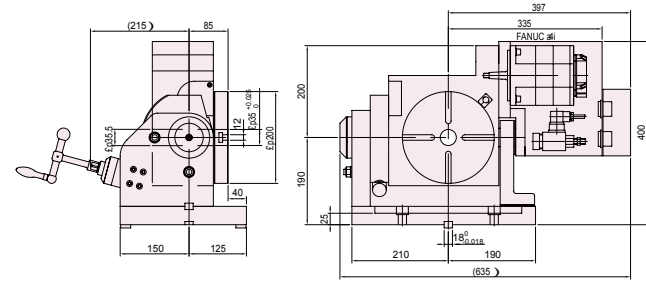

CNCMT-250

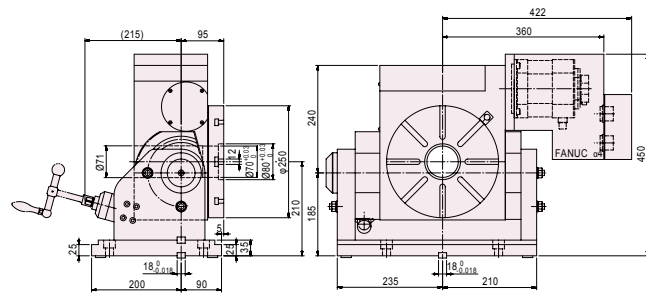

CNCMT-320

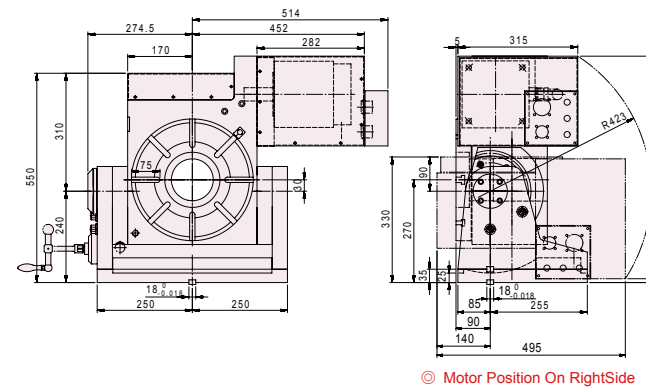

CNCMT-400

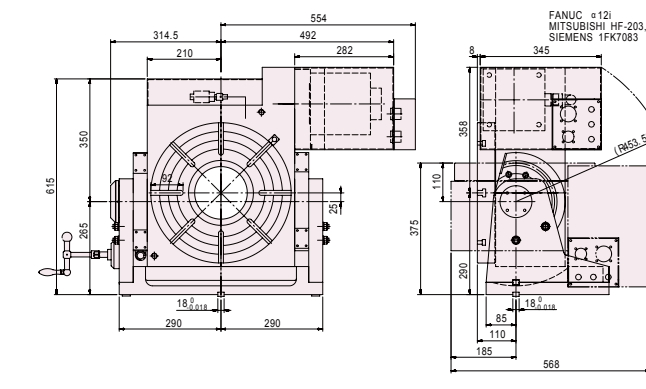

CNCMT-500

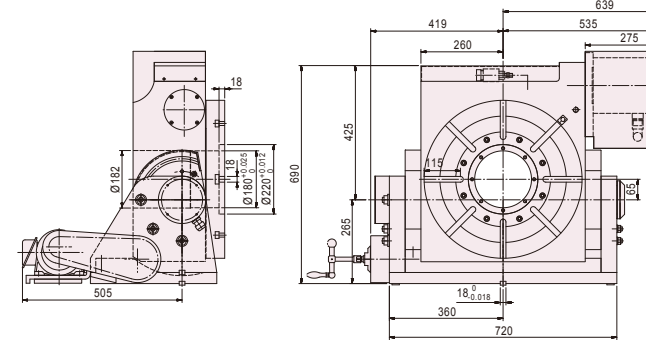

CNCMT-630

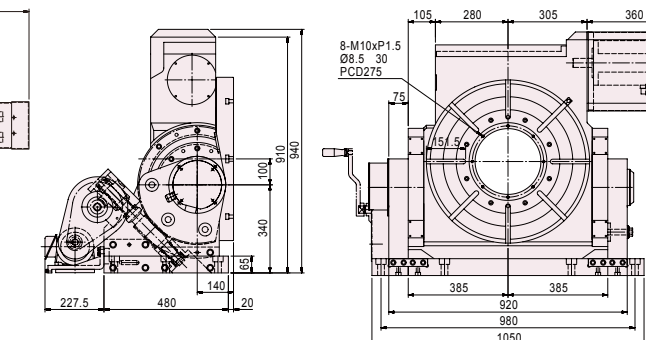

Accuracy Standards							Unit:mm
ITEM	Table top flatness	Parallelism of table top and frame bottom	Runout of table spindle center	Table top runout	Parallelism of tilting axis center line and frame bottom	Parallelism of table top to frame bottom guide block	An encoder measuring instrument should be used for indexing accuracy measurements (Rotating)
CNCMT-200	0.01	0.02	0.01	0.015	0.02	0.02	25"
CNCMT-250	0.01	0.02	0.01	0.015	0.02	0.02	25"
CNCMT-320	0.01	0.02	0.01	0.015	0.02	0.02	15"
CNCMT-400	0.02	0.02	0.01	0.015	0.02	0.02	15"
CNCMT-500	0.02	0.02	0.01	0.015	0.02	0.02	15"
CNCMT-630	0.02	0.02	0.01	0.015	0.02	0.02	15"



- Build-in 3pcs hirth coupling, ensure the indexing accuracy +/- 5 sec.
- Could be direct connected to the 4th. axis on machining-center. Also could be connected the M-code by using G.S. single axis AC/DC/Stepping servo controller.
- Compact design, adapting precision bearing, ensure rigidity and long-term operation.
- Build-in 3 pieces hirth coupling, table will not lifting-up during rotating.

MODEL NO : **NCF-250**



Table Dia.
Type of NC Face Gear Indexer

ITEM / MODEL	NCF-250R	NCF-320R	NCF-400R	NCF-500R
Table Dia (mm / inch)	ø250 / ø9.84	ø320 / ø12.6	ø400 / ø15.75	ø500 / ø19.69
Center Height in Vertical (mm / inch)	185 / 7.28	210 / 8.27	250 / 9.83	310 / 12.21
Table Height in Horizontal (mm / inch)	200 / 7.87	240 / 9.45	250 / 9.83	305 / 12.01
Over all Height in Vertical Without Motor Cover(mm / inch)	315 / 12.40	380 / 14.96	460 / 18.11	560 / 22.05
Thru-Hole Dia (mm / inch)	30 ^{H7} / 1.8 ^{H7}	80 ^{H7} / 3.15 ^{H7}	70 ^{H7} / 2.76 ^{H7}	80 ^{H7} / 3.15 ^{H7}
Width of T-slot (mm / inch)	12 ^{H7} / 0.47 ^{H7}	14 ^{H7} / 0.55 ^{H7}	14 ^{H7} / 0.55 ^{H7}	14 ^{H7} / 0.55 ^{H7}
Width of Guide Block (mm / inch)	18 ^{H7} / 0.71 ^{H7}	18 ^{H7} / 0.71 ^{H7}	18 ^{H7} / 0.71 ^{H7}	18 ^{H7} / 0.71 ^{H7}
Servo Motor type	MELDAS	HF-154T	HF-204S	HF-204S
	FANUC	α8 i	α12 i	α12 i
	SIEMENS	1FK7063	1FK7083	1FK7083
	HEIDENHAIN	QSY116E	QSY155C	QSY155F
Gear Ratio	1:90	1:90	1:90	1:180
Min. increment (degree)	1° or 5°	1° or 5°	1° or 5°	1° or 5°
Max. R.P.M. (rpm) (motor : 2000/ rpm)	22.2	22.2	22.2	11.1
Repeatability (sec.)	Unidirectional	1"	1"	1"
	Bidirectional	2"	2"	2"
N.W.(kgs)	110	240	280	320
Clamp Torque (kg·m)	500	500	600	700
Load capacity in vertical (with tailstock) (kgs)	250	400	500	600

ITEM	Max. Load		Max. Radial Load			Max. Working Inertia	Spindle Drive Torque
	Vertical	Horizontal	F	F _L	F _L	J = $\frac{W \cdot D^2}{8 \times 980}$	F
NCF-250R	W=125 kg	W=300 kg	F=3500kg	F _L =220 kg·m	F _L =140 kg·m	24kg·cm·sec ²	13.5 kg·m
NCF-320R	W=150 kg	W=350 kg	F=5000kg	F _L =500 kg·m	F _L =400 kg·m	102kg·cm·sec ²	54 kg·m
NCF-400R	W=250 kg	W=500 kg	F=6000kg	F _L =600 kg·m	F _L =400 kg·m	102kg·cm·sec ²	54 kg·m
NCF-500R	W=400 kg	W=600 kg	F=7000kg	F _L =700 kg·m	F _L =400 kg·m	102kg·cm·sec ²	54 kg·m

※ GSA remains the right of modification. All specifications can be modified according to customers' requirement.

- Up & backside cable outlet is available, slant motor cover also available.
- Requested pneumatic source : 5 kg·cm² : hydraulic source : 20 kg·cm²
- Standard accessory: eye bolts, clamping blocks

CNC

CNCB

CNCT / CNCMT

NCF

Tailstock

Large Size Table

GCT

PT

APCR / APCI

Controller

Coupling

Accessories

Accuracy Standards								Unit:mm
ITEM	Table top flatness	Parallelism of table top and frame bottom	Runout of table spindle center	Perpendicularity of table top to frame bottom	Table top runout	Perpendicularity of table top to frame bottom guide block	Parallelism of center line between headstock & tailstock to frame bottom guide block	
MODEL								
NCF-250R	0.01	0.01	0.01	0.015	0.01	0.02	0.02	
NCF-320R	0.01	0.01	0.01	0.015	0.01	0.02	0.02	
NCF-400R	0.015	0.015	0.01	0.02	0.015	0.02	0.02	
NCF-500R	0.015	0.015	0.01	0.02	0.015	0.02	0.02	

© Adapting Tailstock→ Refer to P : 34-36
 © To match AC-/DC-/Stepping-Controller→ Refer to P : 53-55

NCF-250R

NCF-320R

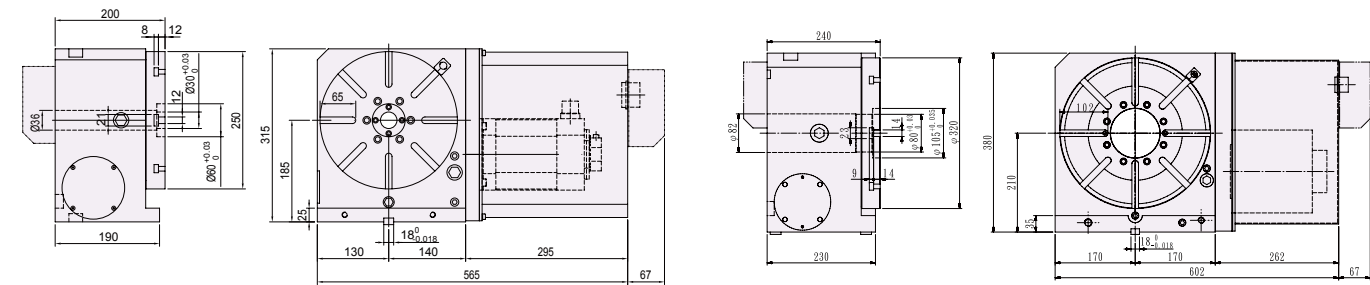

NCF-400R

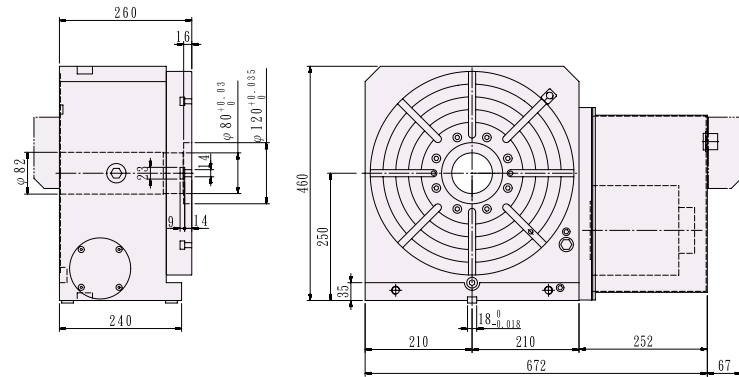

NCF-500R

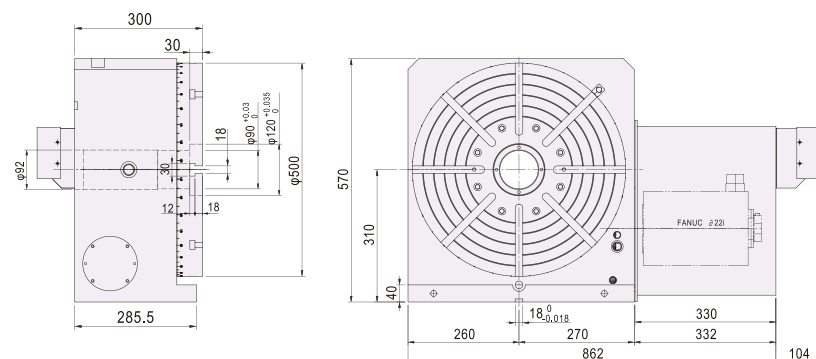

TS-A

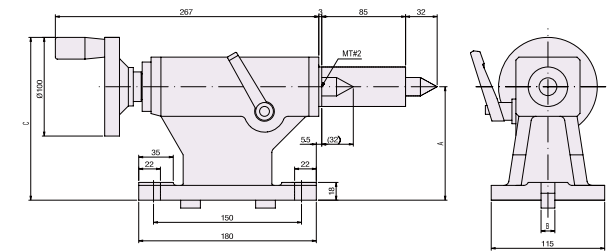

MODEL	A	B	C	Center Taper	Suitable Rotary Table
TS-A115	115	14	165	MT#2	CNC-120R
TS-A135	135	18	185	MT#2	CNC-170R, CNC-170RB
TS-A160	160	18	210	MT#2	CNC-200R, CNC-200RB



TS-B

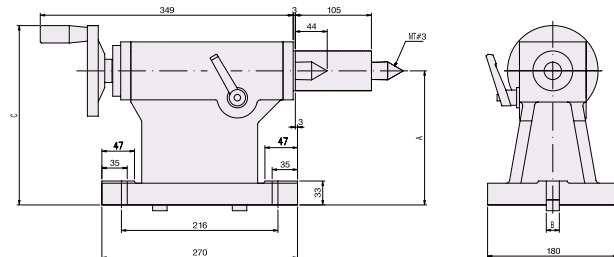

MODEL	A	B	C	Center Taper	Suitable Rotary Table
TS-B185	185	18	250	MT#3	CNC-250R, NCF-250, CNC-250RB
TS-B190	190	18	255	MT#3	CNCMT-200
TS-B210	210	18	275	MT#3	CNC-320R, NCF-320, CNCMT-250
TS-B250	250	18	315	MT#3	CNC-400R, NCF-400
TS-B255	255	18	320	MT#3	CNCT-320
TS-B270	270	18	345	MT#3	CNCMT-320



TS-C

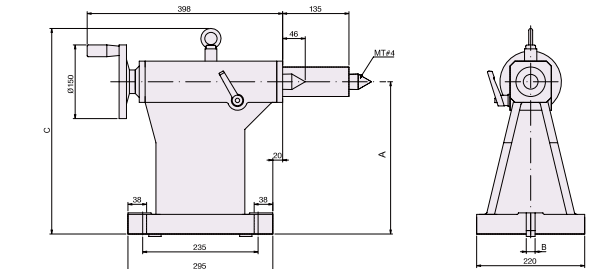

MODEL	A	B	C	Center Taper	Suitable Rotary Table
TS-C310	310	18	420	MT#4	CNC-500R
TS-C400	400	18	510	MT#4	CNC-630R
TS-C480	480	22	590	MT#4	CNC-800R

CNC

CNCB

CNCT / CNCMT

NCF

Tailstock

Large Size Table

GCT

PT

APCR / APCI

Controller

Coupling

Accessories

CNC

CNCB

CNCT / CNCMT

NCF

Tailstock

Large Size Table

GCT

PT

APCR / APCI

Controller

Coupling

Accessories

CNC

CNCB

CNCT / CNCMT

NCF

Tailstock

Large Size Table

GCT

PT

APCR / APCI

Controller

Coupling

Accessories



TS-A(P)

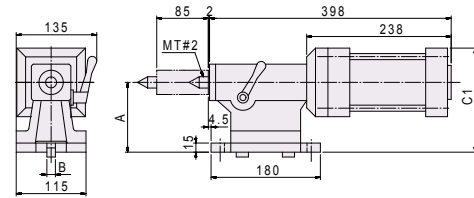

TS-A(H)

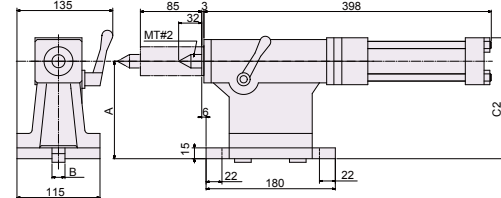

MODEL	A	B	C 1 (P)	C 2 (H)	Center Taper	Suitable Rotary Table
TS-A115 (P/H)	115	14	172	148	MT#2	CNC-120R
TS-A135 (P/H)	135	18	192	168	MT#2	CNC-170R, CNC-170RB
TS-A160 (P/H)	160	18	217	193	MT#2	CNC-200R, CNC-200RB

TS-B(P)

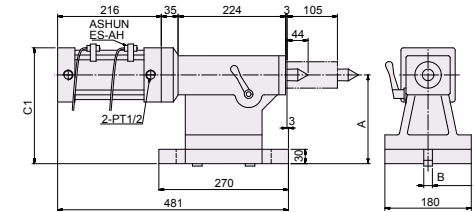

TS-B(H)

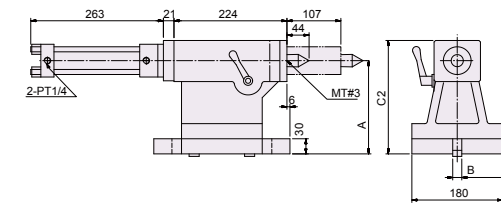

MODEL	A	B	C 1 (P)	C 2 (H)	Center Taper	Suitable Rotary Table
TS-B185 (P/H)	185	18	242	225	MT#3	CNC-250R, NCF-250, CNC-250RB
TS-B190 (P/H)	190	18	247	230	MT#3	CNCMT-200
TS-B210 (P/H)	210	18	267	250	MT#3	CNC-320R, NCF-320, CNCMT-250
TS-B250 (P/H)	250	18	307	290	MT#3	CNC-400R, NCF-400
TS-B255 (P/H)	255	18	312	295	MT#3	CNCT-320
TS-B270 (P/H)	270	18	327	310	MT#3	CNCMT-320

TS-C(P)

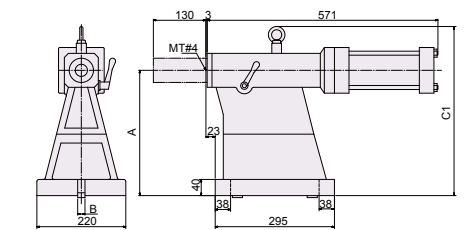

TS-C(H)

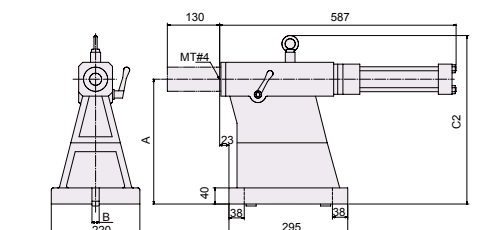

MODEL	A	B	C 1 (P)	C 2 (H)	Center Taper	Suitable Rotary Table
TS-C310 (P/H)	310	18	420	420	MT#4	CNC-500R
TS-C400 (P/H)	400	18	510	510	MT#4	CNC-630R
TS-C480 (P/H)	480	22	590	590	MT#4	CNC-800R

TSA-251S

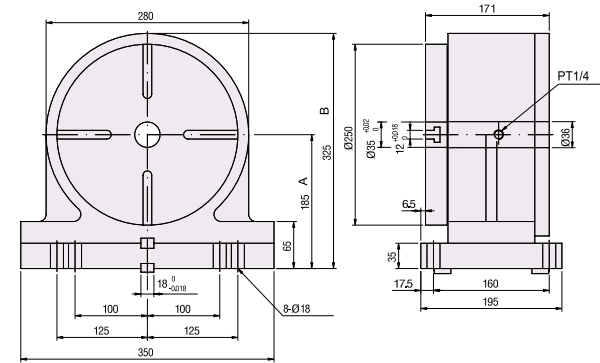

TSA-320S

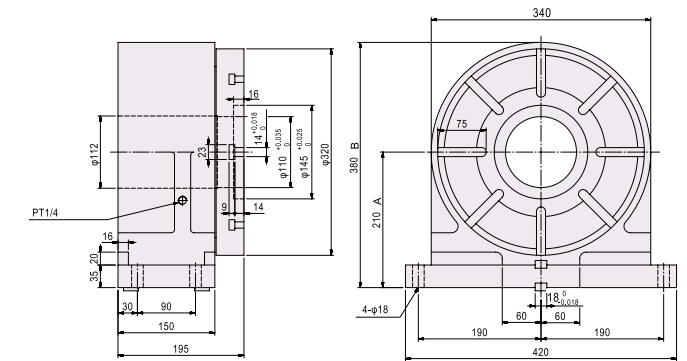

ITEM / MODEL	TSA-120S	TSA-200S	TSA-251S	TSA-320S
Table Dia (mm)	ø120	ø200	ø250	ø320
(A)Center Height in Vertical (mm)	115	160	185	210
(B)Over all Height in Vertical (mm)	196	265	325	380
Thru-Hole Dia (mm)	ø30	ø35	ø35	ø110
Width of T-slot (mm)	10 ^{H7}	12 ^{H7}	12 ^{H7}	14 ^{H7}
Width of Guide Block (mm)	14 ^{H7}	18 ^{H7}	18 ^{H7}	18 ^{H7}
Pneu.clamp force (kg·m)	15(Power 5kg/cm ²)	25(Power 5kg/cm ²)	65(Power 5kg/cm ²)	80(Power 5kg/cm ²)
Hydro.clamp force (kg·m)	25(Power 20kg/cm ²)	50(Power 20kg/cm ²)	115(Power 20kg/cm ²)	150(Power 20kg/cm ²)
N.W. (kgs)	20	45	82	138
Suitable Rotary Table	CNC-120R	CNC-170R CNC-200R	CNC-250R CNC-320R CNC-400R	CNC-320R CNC-400R CNC-500R

CNC

CNCB

CNCT / CNCMT

NCF

Tailstock

Large Size Table

GCT

PT

APCR / APCI

Controller

Coupling

Accessories

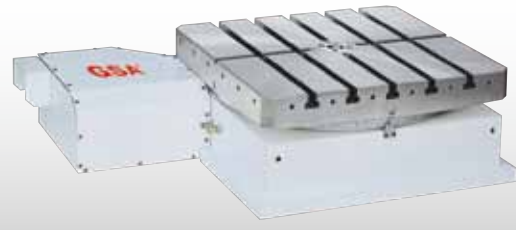

- ⊙ Suitable for Horizontal Machining Center.
- ⊙ Rotating Speed can be reached 33.3 RPM.
- ⊙ Adapting A special anti-wearing/rigid alloy of bronze/nickel worm wheel and hardened steel worm screw ensure long term indexing accuracy.
- ⊙ Double powerful brake system with large size of clamping contact surface suitable for heavy cutting.
- ⊙ Adapting 2 pcs or 3 pcs Hirth Coupling for positioning, Repeatability can be reached +/- 0.5 sec Besides accuracy will not be changed even operation times increasing.
- ⊙ Indexing Accuracy according to customer's requirement: +/- 2 sec. or +/- 3 sec.
- ⊙ All units in Tables are manufactured from high quality materials and workmanship. Every Table has Running/Accuracy testing for at least 48 hours. All electrical parts are imported from Japan/Germany for performance confidence.

ITEM / MODEL		HIT-400	HIT-500
Table Size LxW (mm)		400 x 400	500 x 500
Over all height (mm)		310	310
Center Hole Dia. (mm)		30 ^{H7}	30 ^{H7}
T-slot size (mm)		14 ^{H7}	14 ^{H7}
Rotating direction		CW / CCW	CW / CCW
Power of drive	Clamping/unclamping	Hydraulic 20kg/cm ²	
	Revolving (Servo Motor Type)	MELDAS	HF-204S
		FANUS	α12 i
		SIEMENS	1FK7083
		HEIDENHAIN	QSY155C
		or other brand with same torque as above	
Gear Ratio		1:90	1:120
Max. R.P.M. of working table (rpm)		22.2 (Motor : 2000/rpm)	16.7 (Motor : 2000/rpm)
Min. Increment Degree		1° or 5°	1° or 5°
Max. loading weight (kgs)		500	500
Clamping force (kg)(evenly distributed)		3300	3700
Lifting distance during clamp / unclamp (mm)		0	0
Weight.(kgs)		325	360
Indexing Accuracy (sec.)		±5"	±5"

ITEM / MODEL		HIT-630	HIT-800
Table Size LxW (mm)		630 x 630	800 x 800
Over all height (mm)		285	360
Center Hole Dia. (mm)		40 ^{H7}	55 ^{H7}
T-slot size (mm)		20 ^{H7}	22 ^{H7}
Rotating direction		CW / CCW	CW / CCW
Power of drive	Clamping/unclamping	Hydraulic 25kg/cm ²	
	Revolving (Servo Motor Type)	MELDAS	HF-354S
		FANUS	α22 i
		SIEMENS	1FK7101
		HEIDENHAIN	QSY190C
		or other brand with same torque as above	
Gear Ratio		1:180	1:180
Max. R.P.M. of working table (rpm)		11.1 (Motor : 2000/rpm)	11.1 (Motor : 2000/rpm)
Min. Increment Degree		1° or 5°	1°
Max. loading weight (kgs)		2500	3000
Clamping force (kg)(evenly distributed)		4000	7000
Lifting distance during clamp / unclamp (mm)		0	0
Weight.(kgs)		525	1360
Indexing Accuracy (sec.)		±5"	±5"

※ GSA remains the right of modification. All specifications can be modified according to customers' requirement.

- Up & backside cable outlet is available, slant motor cover also available.
- Standard accessory : eye bolts, clamping blocks

HIT-400

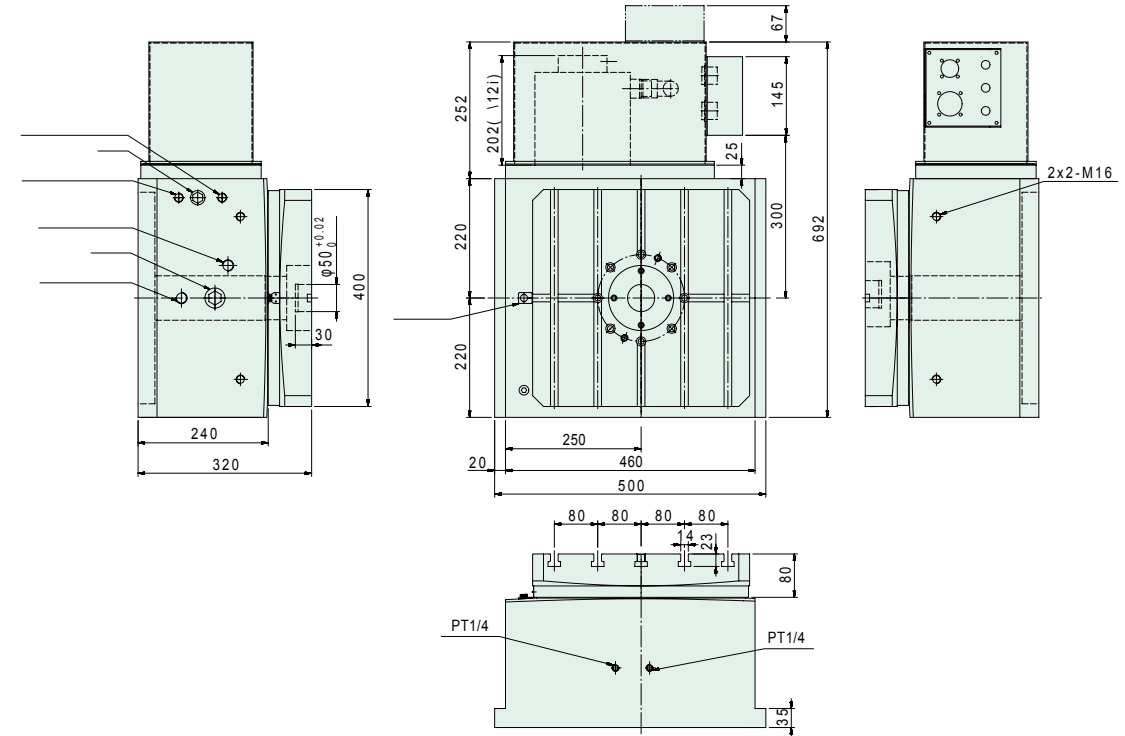

HIT-500

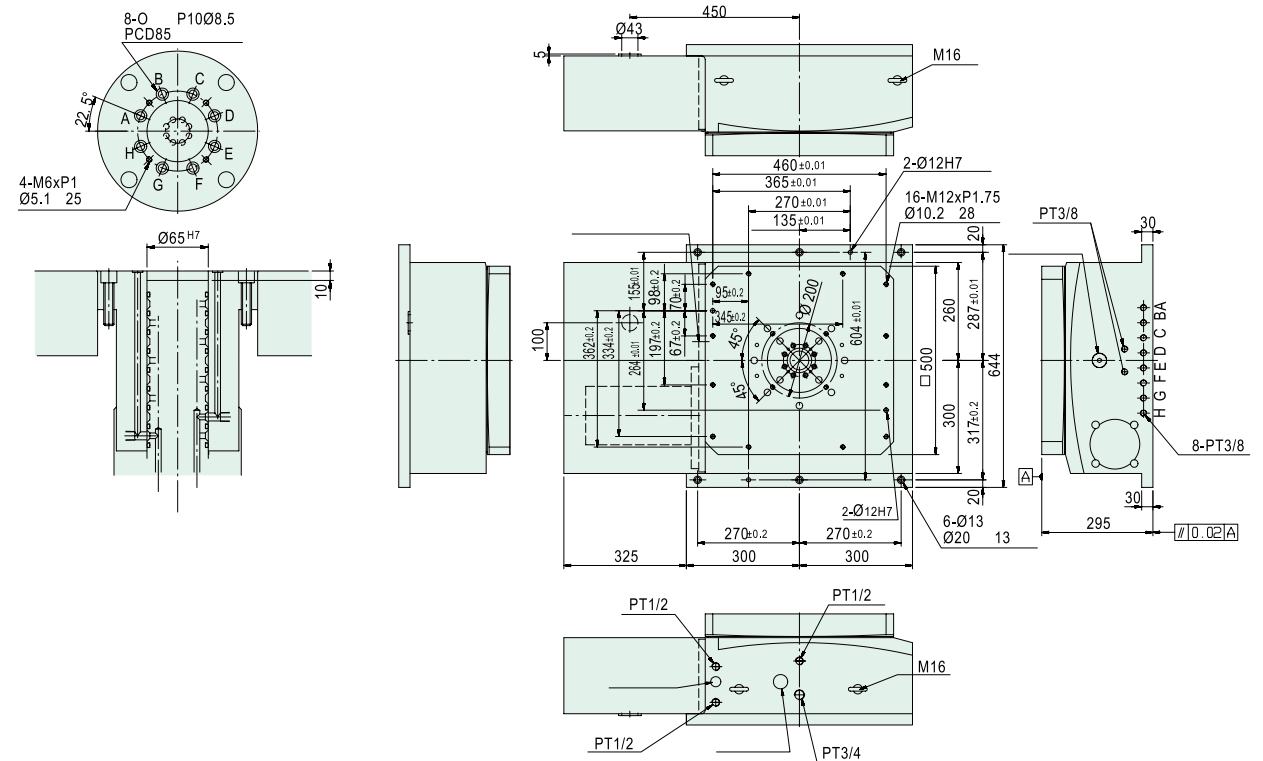

CNC

CNCB

CNCT / CNCMT

NCF

Tailstock

Large Size Table

GCT

PT

APCR / APCI

Controller

Coupling

Accessories

HIT-630

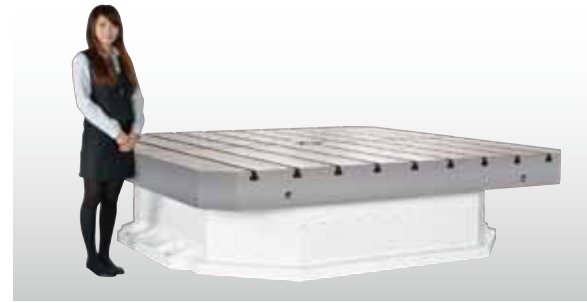
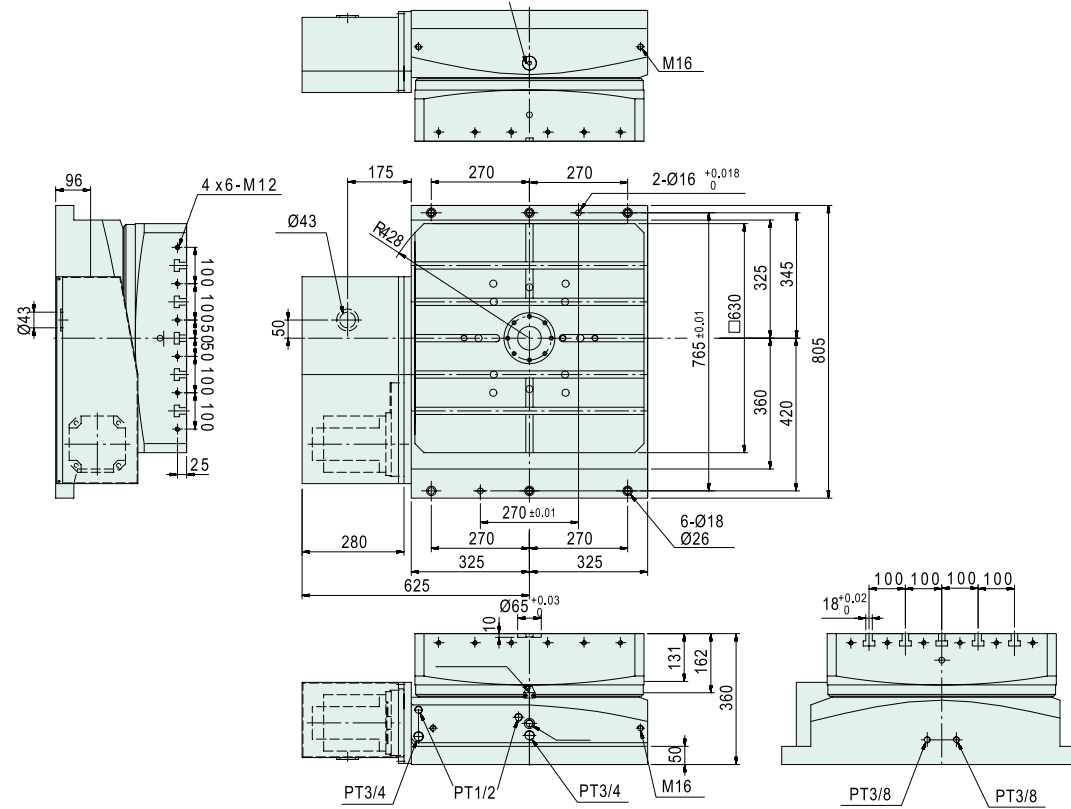

- ◎ Suitable for Horizontal Machining Center, floor type boring machine. For both indexing & simultaneous machine.
- ◎ Hi-Accuracy, Adapting a special anti-wearing alloy of bronze/nickel double-lead worm wheel and hardened steel worm screw ensure long term indexing accuracy.
- ◎ Could be manufactured according to customers' designing and interface of machine Saddle.
- ◎ Hydraulic Clamping, high rigid brake structure for heavy cutting.
- ◎ Table size from size 400mm to 2,500mm or manufactured according to customer's requirement, high loading/accuracy design also available suitable for heavy machining and metrology applications.
- ◎ Build-in hydraulic ports system suitable for Special Machine of Horizontal machining Center and Automobile/Motorbike Industrial.
- ◎ All units in Tables are manufactured from high quality materials and workmanship. Every Table has Running/Accuracy testing for at least 48 hours.
- ◎ All electrical parts are imported from Japan/Germany for performance confidence.
- ◎ Random dividing 0.001 degrees, Indexing Accuracy according to customer's requirement 6 sec, 10 sec. or higher indexing accuracy. (encoder is required)

ITEM / MODEL	HRT-400	HRT-500	HRT-630	HRT-800
Table Size (mm)	400	500	630	800
T-slots size (mm)	14	14	18	22
Table Swing Dia. (mm)	500	660	800	1040
Total Height (mm)	310	295	360	385
Max. Loading (kgs)(evenly distributed)	500	600	1200	2000
Vertical Max. Force (kg)	1585	1880	2080	2080
Load Capacity During Rotating(kg / cm ²)	102	191	405	816
Clamping Force (kgs)	3500	5500	6500	7000
Machining Torque (kg/m)	122	230	330	350
Parallelism Of Table Top and Frame Bottom (mm)	0.015	0.015	0.025	0.03
Repeatability (sec.)	4"	4"	4"	4"

※ GSA remains the right of modification. All specifications can be modified according to customers' requirement.
 ※ To match servo motor type → Refer to P:37 (HIT series)

HIT-800

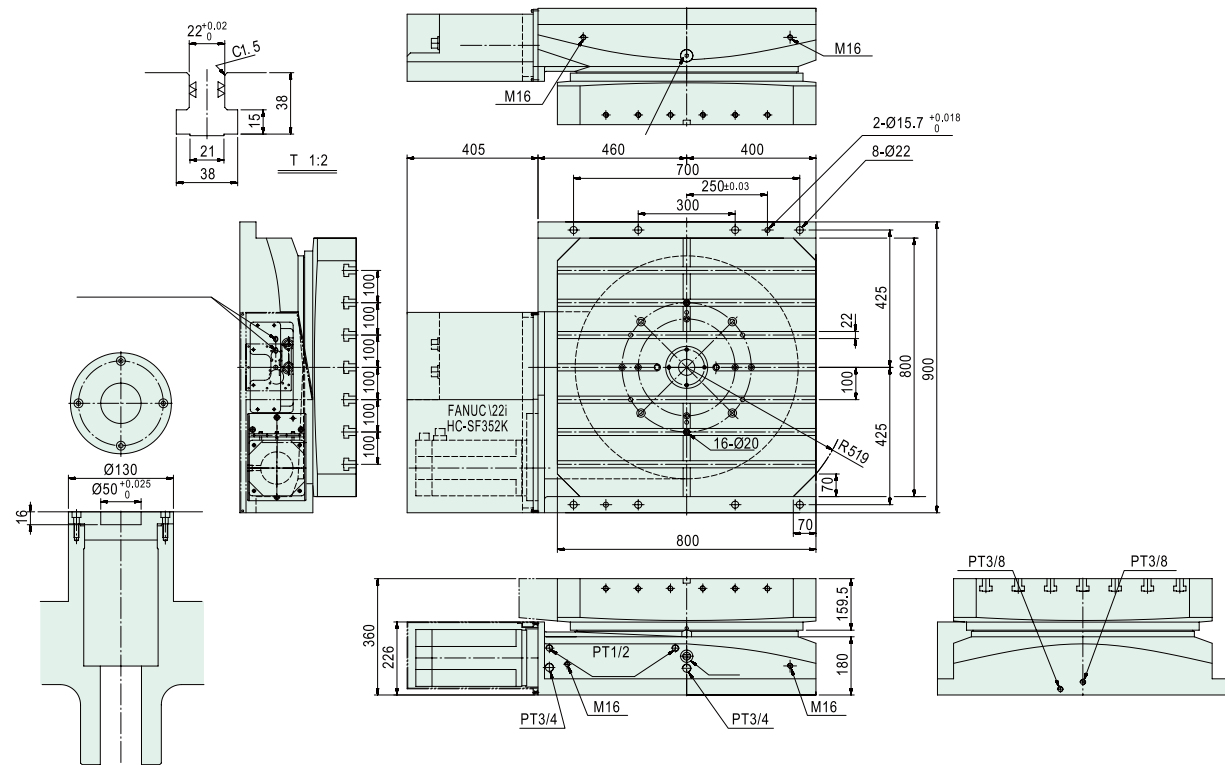

HRT-400

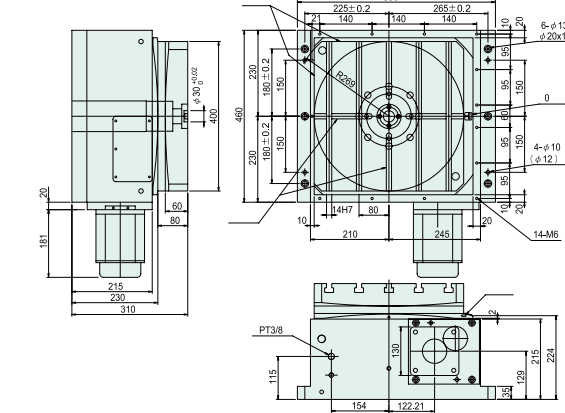

HRT-500

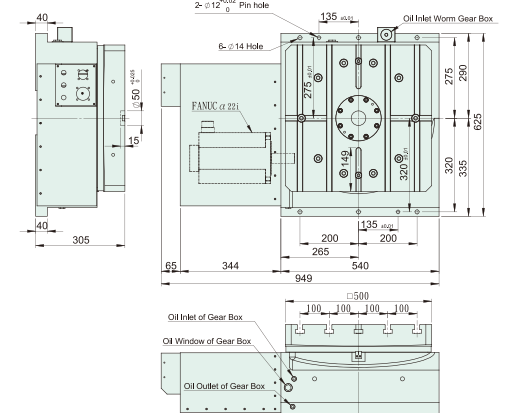

HRT-800

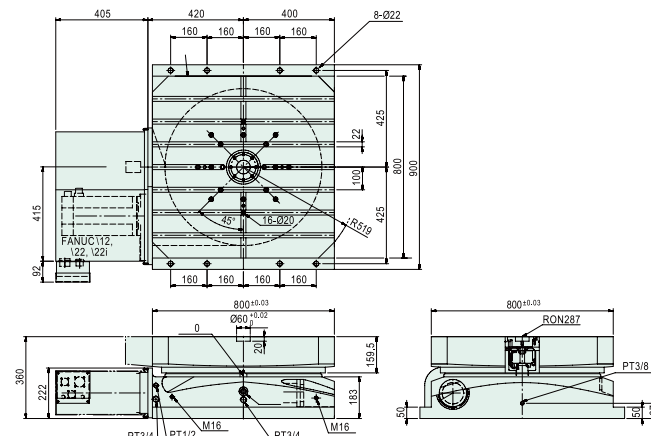

CNC

CNCB

CNCT / CNCMT

NCF

Tailstock

Large Size Table

GCT

PT

APCR / APCI

Controller

Coupling

Accessories

CNC

CNCB

CNCT / CNCMT

NCF

Tailstock

Large Size Table

GCT

PT

APCR / APCI

Controller

Coupling

Accessories

CNC

CNCB

CNCT / CNCMT

NCF

Tailstock

Large Size Table

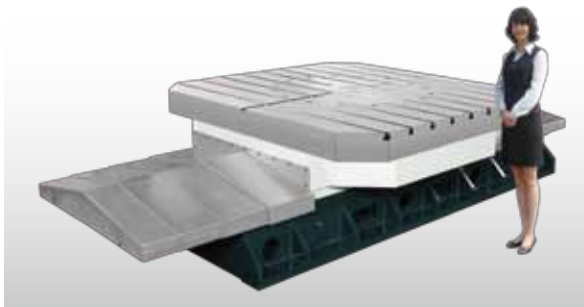

- ◎ Suitable for floor type boring machine, both indexing & simultaneous machine.
- ◎ Hi-Accuracy, Adapting a special anti-wearing alloy of bronze/nickel double-lead worm wheel and hardened steel worm shaft ensure long term indexing accuracy.
- ◎ All units in Tables are manufactured from high quality materials and workmanship. Every Table has Running/Accuracy testing for at least 48 hours. All electrical parts are imported from Japan/Germany for performance confidence.
- ◎ Random dividing 0.001 degrees, Indexing Accuracy according to customer's requirement 5 sec., 10sec. or higher indexing accuracy. (encoder required)
- ◎ 3 face large roller bearing design with excellent price-performance and low maintenance.

ITEM / MODEL	RLT-1500	RLT-2000	RLT-2500
Max. Load in Tons	15	20	30
Table Sizes (mm)	1500 x 1500	2000 x 2000	2500 x 2500
Bearing Diameter (outside/mm)	1280	1600	1800
Max. rpm R/T	4.16	4.16	1.6
Tilting moment (Nm)	211.680	282.240	282.240
Tangential Moment, Clamped (Nm)	19.600	43.900	140.000
Machining Moment (Nm)(S1/S6)	12.000	23.462	39.103
W1 Axis Stroke (mm)	1500	1500	1500
Linear Axis Feed Rate (m/min)	20	20	20
Feeding Force Linear Axis (N)	25.000	25.000	25.000
No. of Guide Rails	2	2	4
Parallelism Between Bottom and Top Surface	0.025	0.025	0.025
Concentricity at Center (mm)	0.01	0.01	0.01

※ GSA remains the right of modification. All specifications can be modified according to customers' requirement.

GCT

RLT-1500

PT

APCR / APCI

Controller

Coupling

Accessories

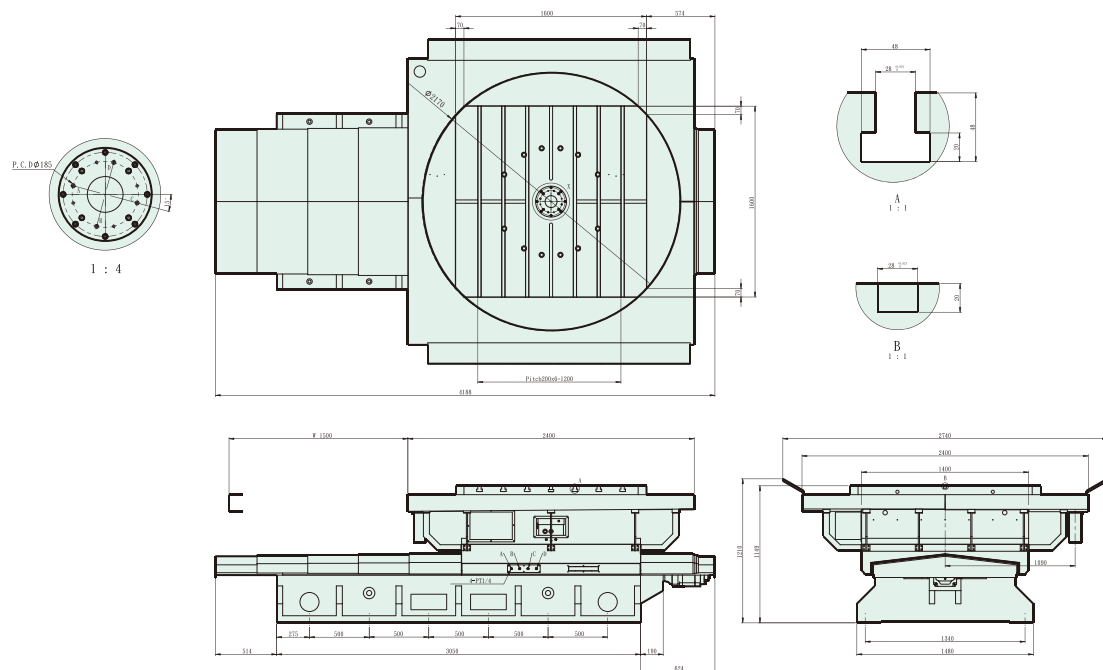

RLT-2000

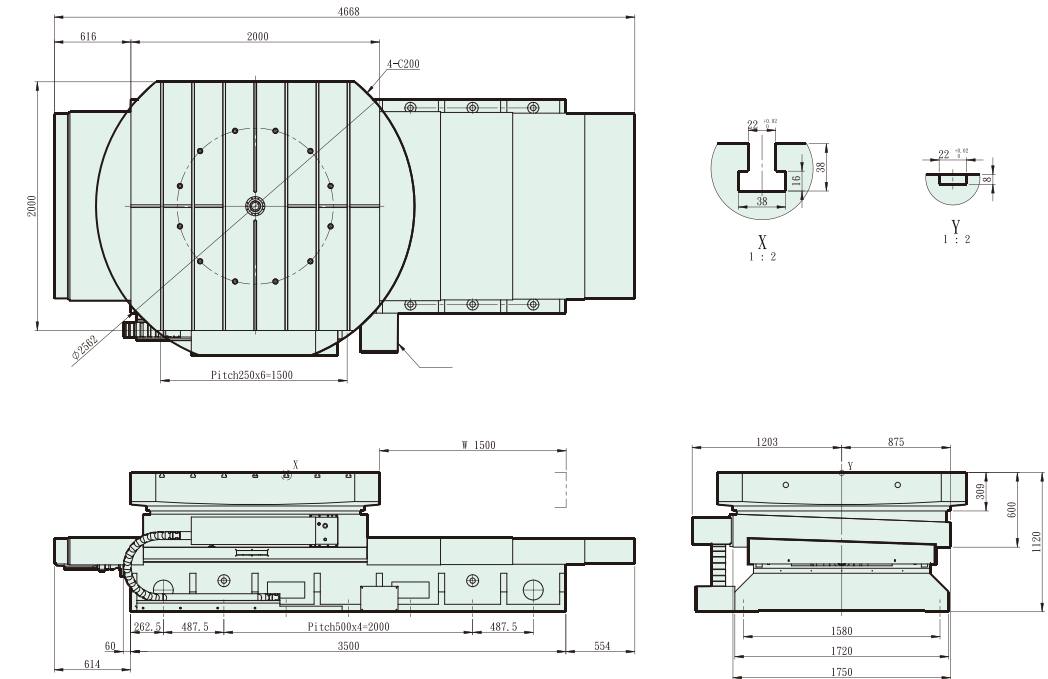

RLT-2500

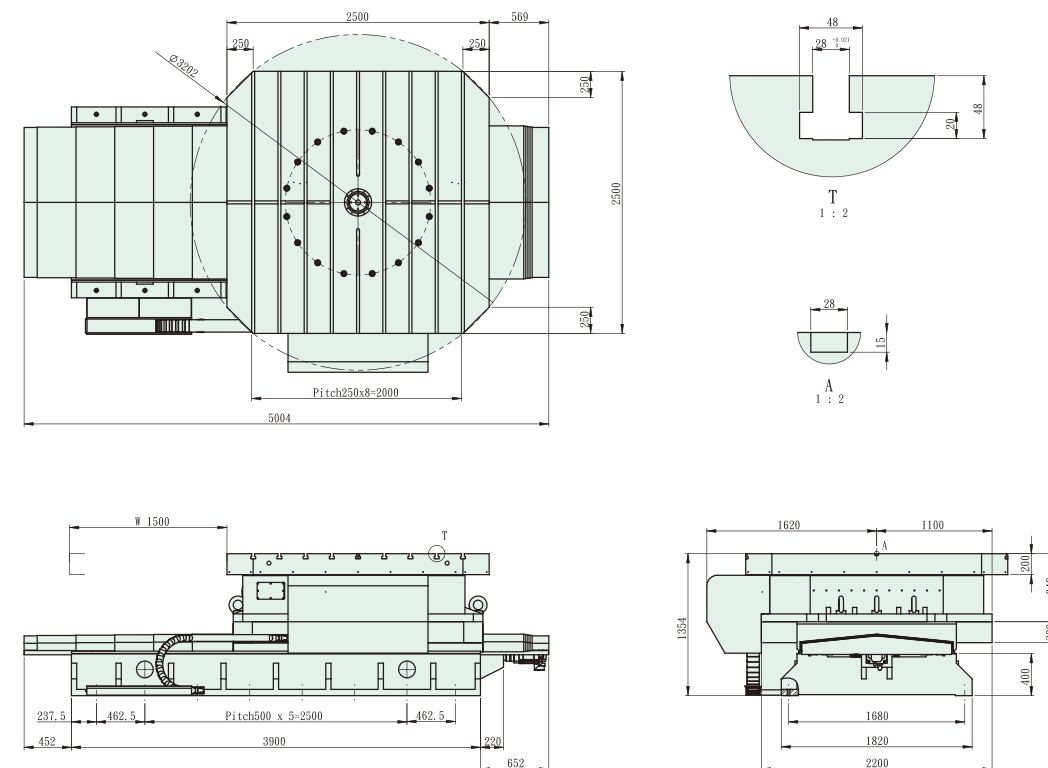

CNC

CNCB

CNCT / CNCMT

NCF

Tailstock

Large Size Table

GCT

PT

APCR / APCI

Controller

Coupling

Accessories



- Table size from size 1,000mm to size 2,000mm can be manufactured in both Vertical/Horizontal position. With high accuracy and high loading capacity which are suitable for heavy machining and metrology applications.
- High Heavy loading capacity **axial-radial Roller Bearings** are incorporated to provide high rigidity.
- All units in Tables are manufactured from high quality materials and workmanship. Every Table has Running/Accuracy testing for at least 48 performance confidence.
- Can be designed by customers' drawings Saddle.
- 0.001 degree increment is standard. Indexing accuracy can be chosen by customers' request. 5 sec. or 10 sec. (encoder is required.)

ITEM / MODEL		CNC-1000HV	CNC-1200HV	CNC-1500HV	CNC-2000HV
Table Dia (mm)		1000	1200	1500	2000
Center Height in Vertical (mm)		650	810	900	1100
Table Height in Horizontal (mm)		530	530	700	800
Over all Height in Vertical Without Motor Cover (mm)		1175	1460	1695	2145
Center Holes (mm)		100 X 60	100 X 60	200 X 70	200 X 70
Width of T-slot (mm)		22 ^{H7}	22 ^{H7}	22 ^{H7}	28 ^{H7}
Width of Guide Block (mm)		22 ^{H7}	22 ^{H7}	28 ^{H7}	36 ^{H7}
Servo motor type	MELDAS	HF-453S	HF-453S	HF-453S	HF-703S
	FANUC	α30 i	α30 i	α30 i	α40 i
	SIEMENS	1FK7103	1FK7103	1FK7103	1FK7105
	HEIDENHAIN	QSY190D	QSY190D	QSY190D	QSY190F
Gear Ratio		1:360	1:360	1:720	1:720
Min. Indexing (degree)		0.001°	0.001°	0.001°	0.001°
Max. R.P.M. (rpm) (motor : 2000 / rpm)		5.56	5.56	2.78	2.78
Hydro. clamp force (kg·m) (P:35kg / cm ²)		1100	1100	1500	2000
Indexing Accuracy Class (sec.)		A	60"	A	60"
		High Accuracy Rotary Table Refer to P59 chart 2			
Indexing Accuracy	Encoder	5" / 10"	5" / 10"	5" / 10"	5" / 10"
Repeatability	Encoder	4"	4"	4"	4"
Max. Machining Force (kg·m)		500	500	600	700
N.W. (kgs)		2500	3500	6000	8000
Max. Load	Vertical	W=1500 kg	W=2000 kg	W=3000 kg	W=4000 kg
	Horizontal	W=3500 kg	W=5000 kg	W=8000 kg	W=10000 kg
Max. Radial Load		F=5000 kg	F=6000 kg	F=7000 kg	F=8000 kg
		FxL=1100 kg·m	FxL=1100 kg·m	FxL=1500 kg·m	FxL=2000 kg·m
		FxL=2000 kg·m	FxL=2500 kg·m	FxL=3000 kg·m	FxL=3500 kg·m

※ GSA remains the right of modification. All specifications can be modified according to customers' requirement.

CNC-1000

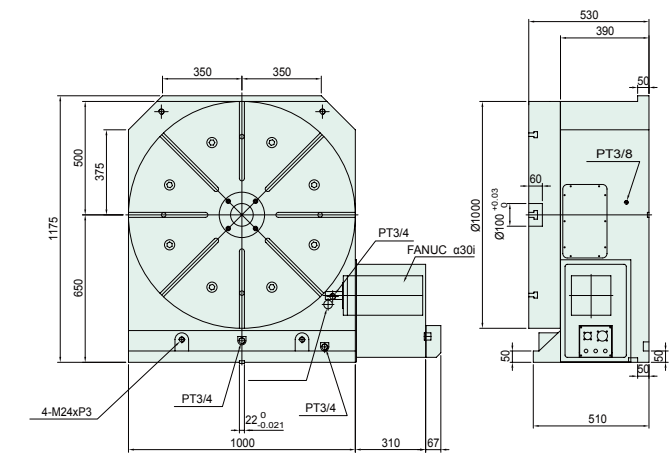

CNC-1200

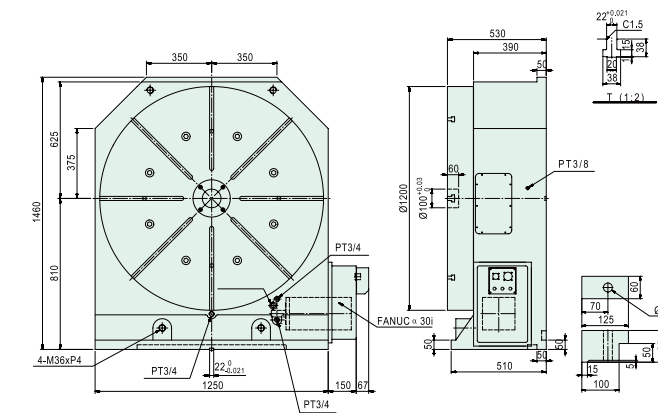

CNC-1500

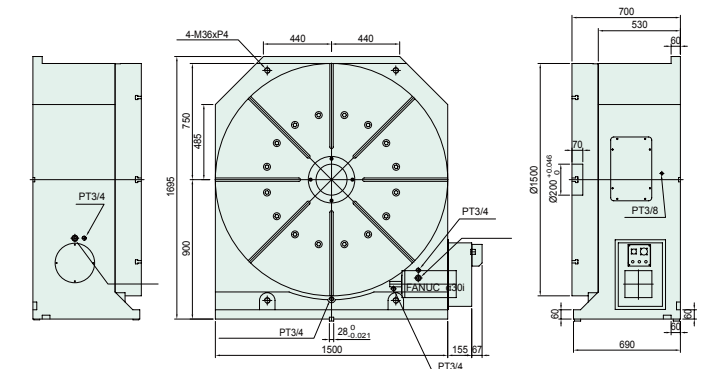

CNC-2000

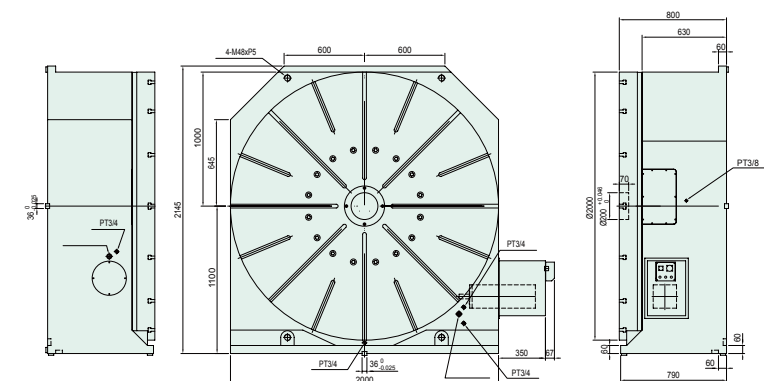

CNC

CNCB

CNCT / CNCMT

NCF

Tailstock

Large Size Table

GCT

PT

APCR / APCI

Controller

Coupling

Accessories

CNC

CNCB

CNCT / CNCMT

NCF

Tailstock

Large Size Table

GCT

PT

APCR / APCI

Controller

Coupling

Accessories

CNC

CNCB

CNCT / CNCMT

NCF

Tailstock

Large Size Table

GCT

PT

APCR / APCI

Controller

Coupling

Accessories

CNC

CNCB

CNCT / CNCMT

NCF

Tailstock

Large Size Table

GCT

PT

APCR / APCI

Controller

Coupling

Accessories

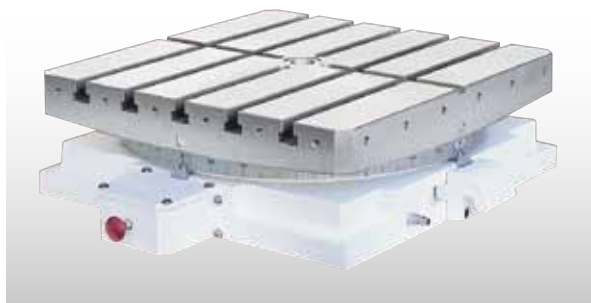

- ◎ Suitable for the high accuracy machining such as Boring-Milling, Grinding-Machine.
- ◎ Build-in 2 pieces hirth coupling for positioning, indexing accuracy +/- 3 sec, ensure a long-term operation.
- ◎ Powerful clamping design, allow heavy cutting and boring.
- ◎ Clamping / Unclamping by pneumatic, easy operation.
- ◎ The body is FC-35 cast iron, durable and will last longer without deformation.

MODEL NO : **GCT-600**

● Size of Table
● Type of precision index table



2 PCS hirth coupling

ITEM / MODEL	GCT-301	GCT-450	GCT-600	GCT-700	GCT-800	GCT-1000	GCT-1200	
Table size L x W (mm)	300X300	450X450	600X600	700X700	800X800	1000X1000	1200X1200	
Height (mm)	140	170	200	220	280	300	340	
Spindle hole (mm)	ø25	ø30	ø40	ø40	ø60	ø60	ø80	
T-slot (mm)	14	18	20	20	22	22	22	
Table rotating	clockwise and counterclockwise							
Table Lifting up & Clamp down stroke (mm)	5	5	5	5	8	8	8	
Driving	Longitudinal	Pneu. Pressure 5~8 kg/cm ²					Pneu. 5~8 kg/cm ² Hydro. 30 kg/cm ²	
	Revolving	Manual						
Number of division (degree)(evenly distributed)	15°	1° or 5°						
Max. load weight in theory (kgs)	1200	2400	3400	3400	4500	6000	7000	
Allowable load weight (kgs)	500	1000	2000	2000	3000	5000	6000	
Clamping capacity (kgs)	-	2200	3200	3200	5400	5400	8100	
N.W. (kgs)	90	200	400	600	900	1200	2000	

※ GSA remains the right of modification. All specifications can be modified according to customers' requirement.

GCT-301~1200

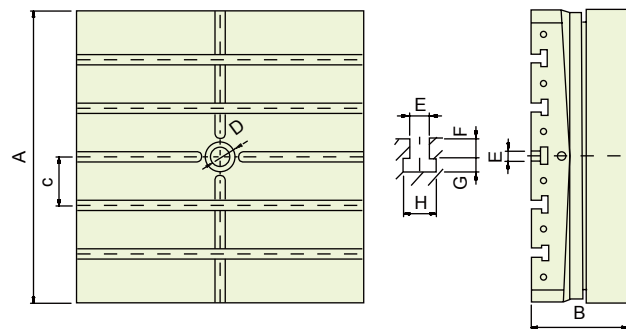

	GCT-301	GCT-450	GCT-600	GCT-700	GCT-800	GCT-1000	GCT-1200
A	300	450	600	700	800	1000	1200
B	140	170	200	220	280	300	340
C	100	100	100	125	100	150	200
D	-	30	40	40	60	60	80
E	12	18	20	20	22	22	22
F	14	16	20	20	23	23	23
G	9	12	14	14	15	15	15
H	23	28	35	35	38	38	38

Accuracy Standards								Unit:mm	
ITEM MODEL	Concentricity of center spigot	Flatness of table surface	Table oscillation	Parallelism between bottom and top surfaces	T-slot right angle	Right angle of table side	Concertricity and T-slot side	Test by NIKON "Auto collimator"	
								Divide into 4 equal parts	Divide into 72 equal parts
GCT-301	0.01	0.01	0.01	0.01	0.015	0.015	0.015	±2"	±3"
GCT-450	0.01	0.015	0.01	0.015	0.015	0.015	0.015	±2"	±3"
GCT-600	0.01	0.02	0.015	0.02	0.02	0.02	0.02	±2"	±3"
GCT-700	0.01	0.02	0.015	0.02	0.02	0.02	0.02	±2"	±3"
GCT-800	0.01	0.02	0.015	0.02	0.02	0.02	0.02	±2"	±3"
GCT-1000	0.01	0.03	0.02	0.03	0.03	0.03	0.02	±2"	±3"
GCT-1200	0.01	0.03	0.02	0.03	0.03	0.03	0.02	±2"	±3"

Machining Status

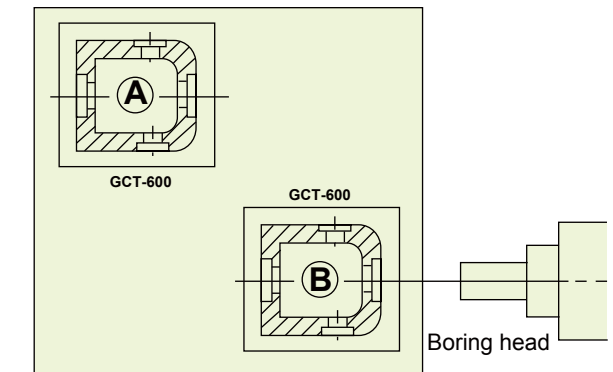
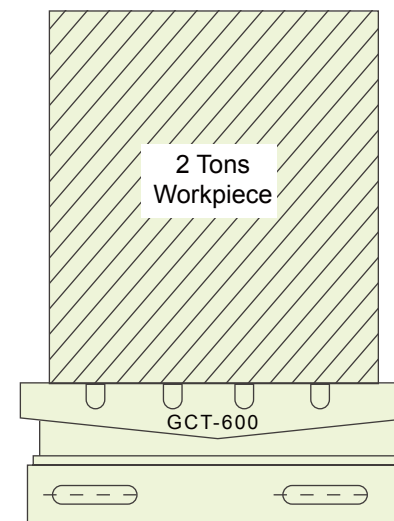

Allowed Loading Chart

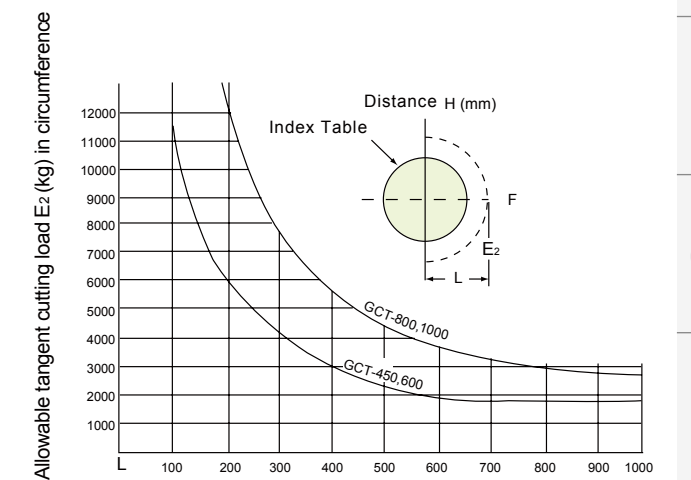
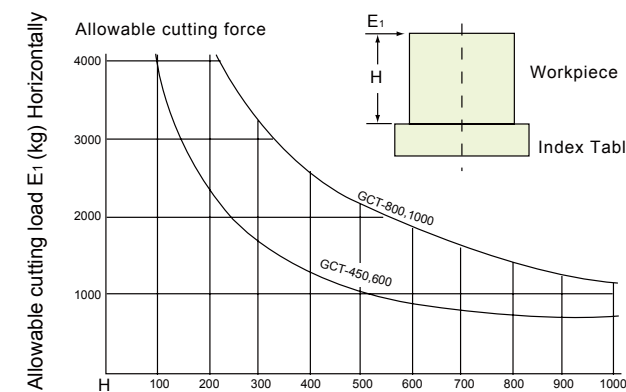

CNC

CNCB

CNCT / CNCMT

NCF

Tailstock

Large Size Table

GCT

PT

APCR / APCI

Controller

Coupling

Accessories

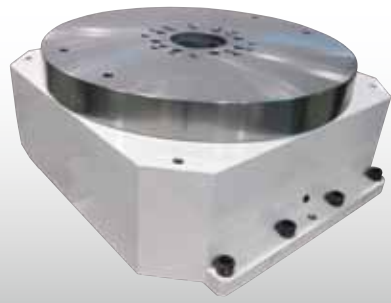

- ⊙ Suitable for round-type special-purpose machine and horizontal M/C for high precision machining.
- ⊙ Build-in 3 pieces hirth coupling, without lifting up and down during rotating, shorten the indexing cycle, ensure positioning.
- ⊙ Powerful clamping design, allow heavy cutting and boring.
- ⊙ Indexing accuracy ± 4 sec. ensure a long-term operation.

MODEL NO : **PT-340-40**

● Name of Table
● Size of Table
● Number of Position



ITEM / MODEL	PT-200	PT-340	PT-470	PT-600	PT-800			
Table Diameter (mm)	Ø200	Ø340	Ø470	Ø600	Ø800			
Table Center Hole Diameter (mm)	Ø30 ^{H6}	Ø65 ^{H6}	Ø90 ^{H6}	Ø110 ^{H6}	Ø120 ^{H6}			
Table Center Hole Depth (mm)	30	11	11	11	40			
Table Center Through Hole Diameter (mm)	Ø27	Ø30.5	Ø41	Ø53	Ø80			
Table Overall Height (mm)	175	210	240	260	305			
Hydraulic Pressure (kg/cm ²)	35	35	35	35	35			
Index Number (standard)(division)	4, 6, 8, 12, 24 (one of them)							
Index Number (available)(division)	*2, 3, 5, 9.....available by special order							
Rotating Direction	CW & CCW							
Indexing Accuracy (accumulative)(sec.)	$\pm 4''$	$\pm 4''$	$\pm 4''$	$\pm 4''$	$\pm 4''$			
Repetitive Accuracy (sec.)	$\pm 1''$	$\pm 1''$	$\pm 1''$	$\pm 1''$	$\pm 1''$			
Rotation Torque (kg-m)	25	57	86	144	280			
Permissible Instant Inertia WR ² (kg-m ²)	7	21.25	45	125	300			
Indexing Time of 90° Degrees (s)	1.7	2.3	3.4	5.4	9.6			
Clamping Torque	F		kgf	1260	1560	3970	6448	9600
			N	12340	15200	38500	63000	94000
	FXL		kg-m	108	332	1428	1980	4000
			N-m	1060	3250	13390	19400	39200
FXH		kg-m	55	145	550	840	1950	
		N-m	541	1423	5390	8232	19110	
Load Capacity	O°		kg	120	500	700	1250	2400
Weight (Net)(kg)				50	115	270	480	900

※ GSA remains the right of modification. All specifications can be modified according to customers' requirement.

Application of Products

Pallet Changer for HMC or Moving Column VMC



Guaranteed Inspection Accuracy

Inspection items	PT-200	PT-340	PT-470	PT-600	PT-800
Concentricity Center Hole (mm)	0.02	0.02	0.02	0.02	0.02
Table Run Out (mm)	0.02	0.02	0.02	0.02	0.02
Table Straightness (mm)	0.02	0.02	0.02	0.02	0.02
Parallelism Between Plate and Base (mm)	0.02	0.02	0.02	0.03	0.03

PT-340

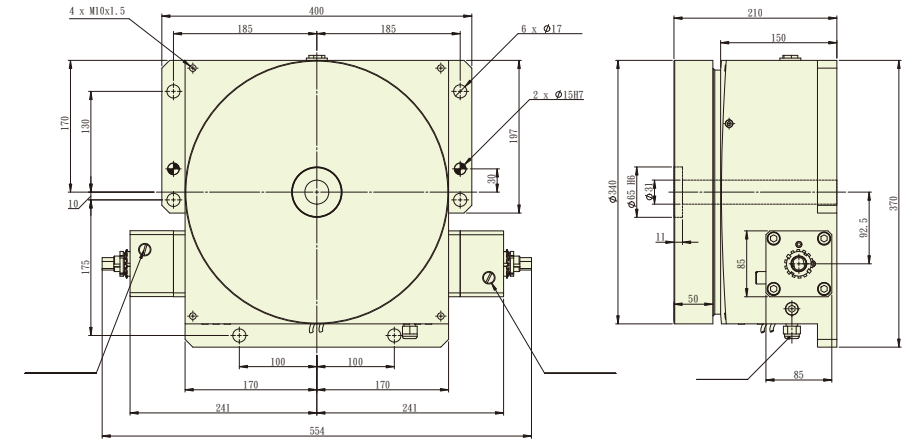

PT-470

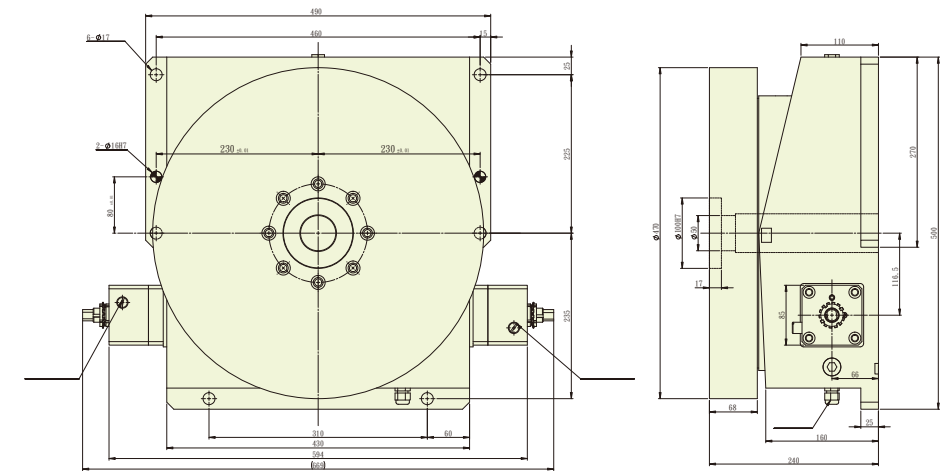

PT-600

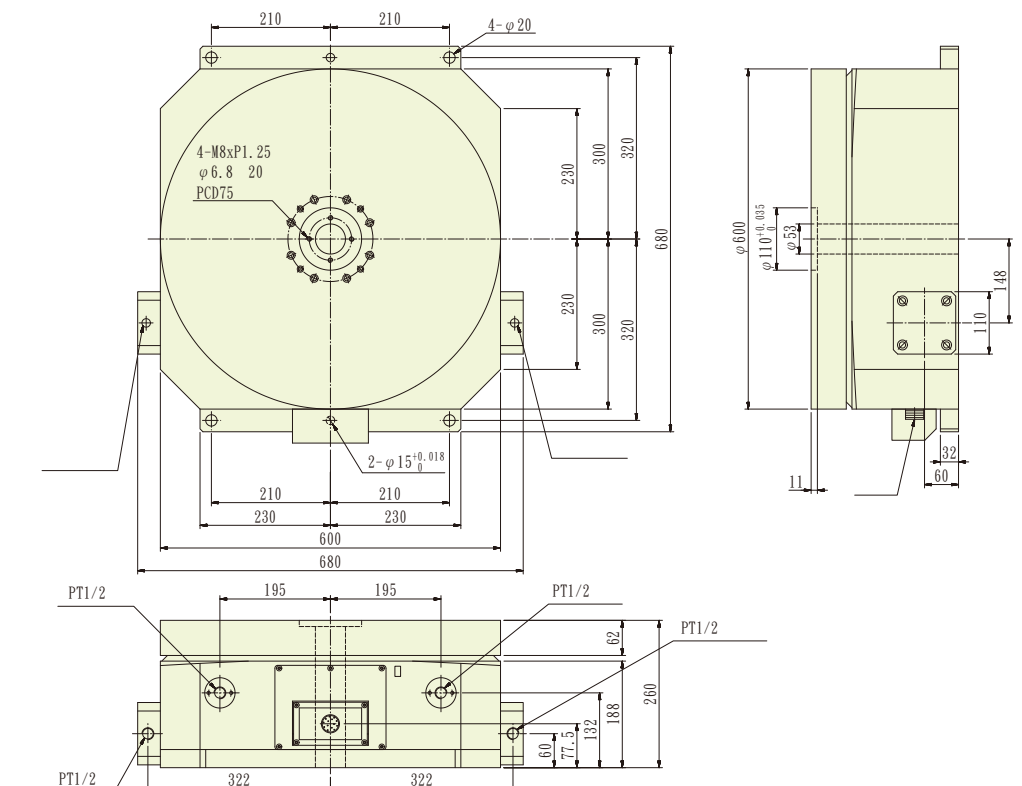

CNC

CNCB

CNCT / CNCMT

NCF

Tailstock

Large Size Table

GCT

PT

APCR / APCI

Controller

Coupling

Accessories

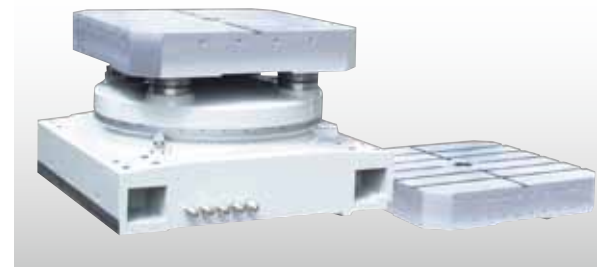

- High accuracy and tested modular system for Table (Receiver) & single/Multi Pallets design. Especially suitable for new Horizontal Machining Centers as well as for existing Customers' Design Horizontal Table/Pallets manufacturing.
- All units Table(Receiver) & single/Multi Pallets are manufactured from high quality materials and workmanship. Every Table has Running/Accuracy testing for at least 48 hours. All electrical parts are imported from Japan/Germany for performance confidence.
- Can be finished according to DIN, ISO or Customers' design, All pallets are exchangeable for every Index Tables or CNC Tables (Receivers) Pallets changing type can be Swing or Forward/Backward designed.
- By high accuracy 4 pcs Cones/Cups.
- By Hydraulic 4 pcs Pull Studs or Clamping Plate.
- Can be designed by customers' drawings Saddle.
- 1 degree or 0.001 degree increment are optional Can be chosen by customers' request. +/- 2 sec. or +/- 3 sec.(APR series:encoder is required)

ITEM / MODEL	APCR/APCI 400	APCR/APCI 500	APCR/APCI 630	APCR/APCI 800	APCR/APCI 1000
Pallet Dimensions (mm)	400	500	630	800	1000
T-slots Size (mm)	14	14	18	22	22
Rounded Corners (mm)	500	628	800	1040	1570
Total Height (mm)	370	550	505	525	550
Clamping Station Weight (kgs)	365	600	750	900	1100
Pallet Weight (kgs)	75	120	170	200	300
Max. Loading (kgs)(evenly distributed)	500	600	1200	2000	3000
Clamping Force (kgs)	3500	5500	6500	7000	8000
Machining Torque (kg/m)	122	230	330	350	450
Parallelism (mm)	0.015	0.015	0.025	0.03	0.03
Repeatability (mm)	0.01	0.01	0.01	0.01	0.01

※ GSA remains the right of modification. All specifications can be modified according to customers' requirement.

Accuracy Standards								Unit:mm
ITEM	Concentricity of center spigot	Table oscillation	Parallelism between bottom and top surfaces	T-slot right angle	Right angle of table side	Concentricity and T-slot side	Table top flatness	
MODEL								
APCI-400	0.01	0.015	0.02	0.02	0.02	0.02	0.02	
APCI-500	0.01	0.015	0.02	0.02	0.02	0.02	0.02	
APCR-630	0.01	0.015	0.02	0.02	0.02	0.02	0.02	
APCR-800	0.01	0.015	0.025	0.025	0.025	0.021	0.025	
APCR-1000	0.01	0.015	0.025	0.025	0.025	0.033	0.025	

APCI-400

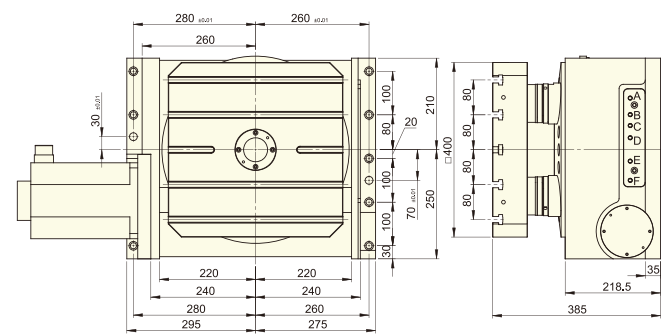

APCI-500

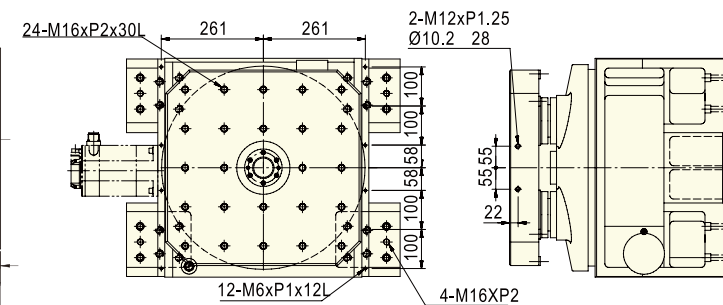

APCR-630

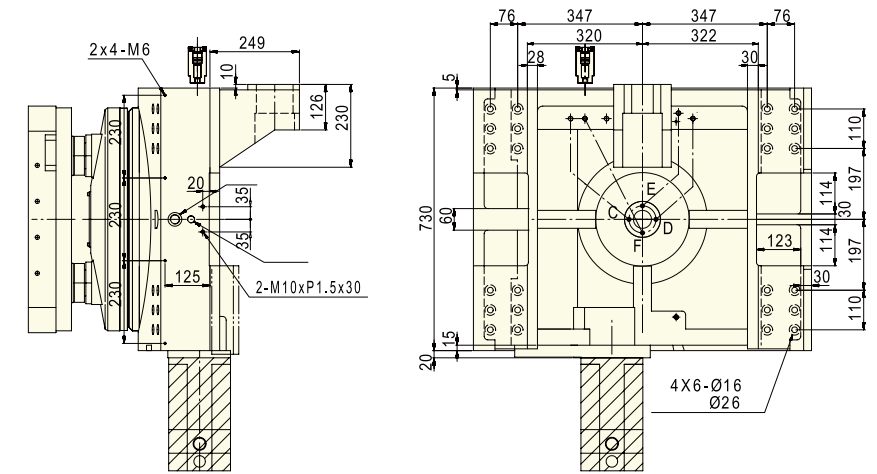

APCR-800

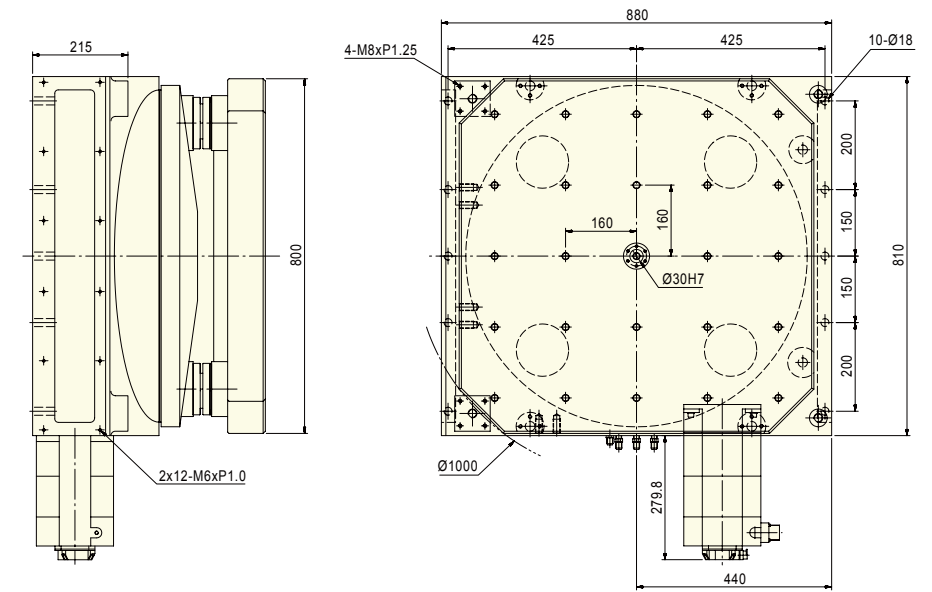

APCR-1000

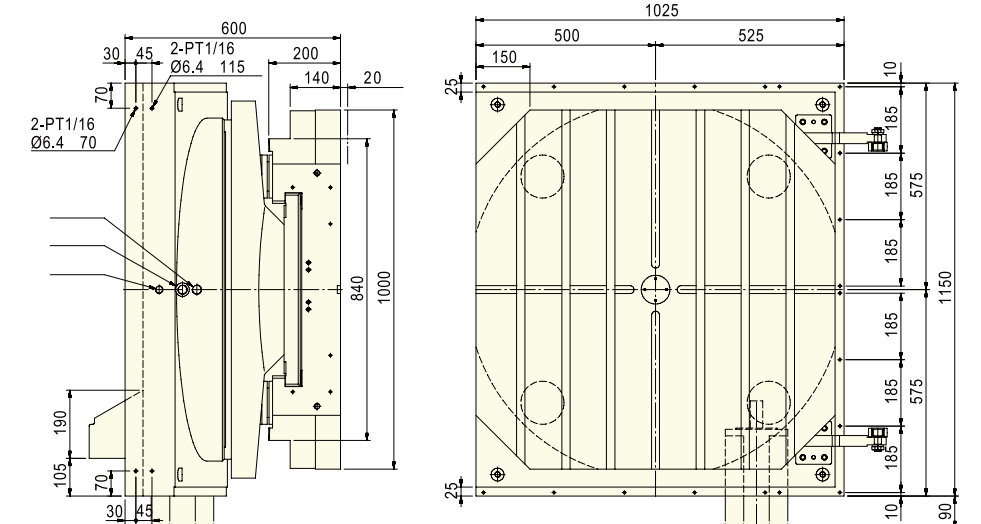

CNC
CNCB
CNCT / CNCMT
NCF
Tailstock
Large Size Table
GCT
PT
APCR / APCI
Controller
Coupling
Accessories

CNC
CNCB
CNCT / CNCMT
NCF
Tailstock
Large Size Table
GCT
PT
APCR / APCI
Controller
Coupling
Accessories

CNC

CNCB

CNCT / CNCMT

NCF

Tailstock

Large Size Table

GCT

PT

APCR / APCI

Controller

Coupling

Accessories



- Easy operation, saving space of machine shop.
- Connecting with-CNC Rotary Table to M-Code of CNC M/C for equal division indexing machining.
- The best solution for conventional M/C which could not retrofitted 4th axis.
- Program capacity = 9 sets, minimum increment 0.001°

Suitable Rotary Table :

CNC-120R	CNC-200RB	CNC-400R	CNCMT-200
CNC-170RB	CNC-250R	CNC-500R	CNCMT-320
CNC-170R	CNC-250RB	CNC-630R	NCF-250
CNC-200R	CNC-320R	CNC-800R	

ITEM	SPECIFICATION	ITEM	SPECIFICATION
Min. Increment	0.001°	Key-Lock Function	Set Parameter # 7 to (1)
Programmable Angle	1-999°	Mode Selection After Power On	Program mode / Run mode
Max. Equal Dividing	2-999 equal dividing	Backlash Adjustment	Parameter # 17
Emergency Stop	Whole system stop	Previous Step Display Function	Pushing "WRITE" key
Input System	key board	Next Step Display	Pushing "READ" key
Zero Return	Can be compensated by software / hardware	Standard Parameter Function	Parameter # 1-17 can be set easily
Feed rate	F1~F2000 (degree/sec.)	Motor	Meldas HC motor with feed back unit
Program Capacity	Nine programs, 99 steps for each program	Connection Cable	For input power/pulse coder, motor power cycle start / finish signal / brake signal
Jump Function	Jump to sub-program (code. 95)	Input Power	AC 240V/50Hz / three phase
Loop Count	Up to 999 times per step	Voltage	Below 48V/DC

Example

Step 1	Turn (Power) switch on.	Step 5	Push [PROG] to feed-rate (F), input "30"
Step 2	Push and hold [PROG] and release display becomes blinking	Step 6	Push [FUNC] to loops (L), input "4"
Step 3	Push and hold [CLR] for 5 sec. or "00" display	Step 7	Push [PROG] display become no blinking
Step 4	Key in "9000"	Step 8	Push [START] table start rotating 4 times

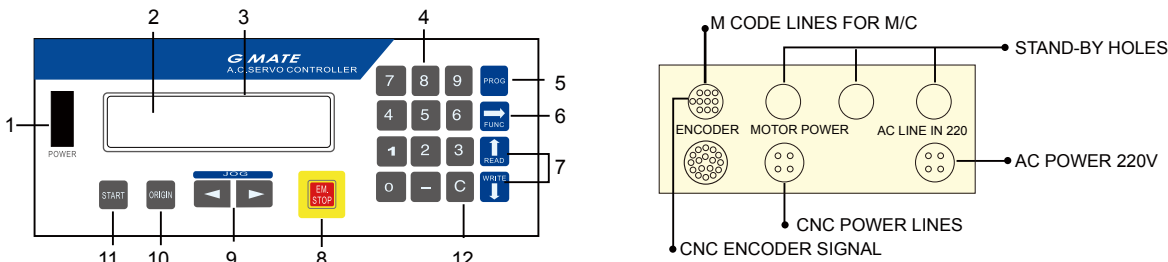

	1. POWER SWITCH		8. EMERGENCY STOP BUTTON • The rotating table shows down and stop. • When (11) CYCLE START BUTTON is depressed again, the table rotates the remaining angle of the program.
	2. PROGRAM STEP DISPLAY SCAN Present the step number you are on.		
	3. DATA DISPLAY SCAN To show either position, step angle feedrate or loop count.		9. JOG BUTTON To jog the movement at single step, holding for rapid movement after 150 pulse.
	4. DATA ENTER KEYS Enter in data of program		
	5. MODE BUTTON To select in the PROGRAM or RUN mode • If the display is steady, you are in RUN mode. • If it is flashing on and off, you are in PROGRAM mode.		10. ZERO RETURN BUTTON In the RUN mode, push the button will return the table to Zero Point.
	6. FUNCTION BUTTON To view the piece of data in the display scan of the controller.		
	7. STEP READ or WRITE BUTTON • Scans step number from 1-99. • To read or write preventor or next step.		11. CYCLE START BUTTON The table rotates as programmed.
	12. CLEAR BUTTON • In the RUN mode, it resets the "P" display to zero. • In the PROGRAM mode, it is used to clear the current line or collect the error		

CNC

CNCB

CNCT / CNCMT

NCF

Tailstock

Large Size Table

GCT

PT

APCR / APCI

Controller

Coupling

Accessories



- Easy operation, saving space of machine shop.
- Connecting with-CNC Rotary Table to M-Code of CNC M/C for equal division indexing machining.
- The best solution for conventional M/C which could not retrofitted 4th axis.
- Program capacity = 9 sets, minimum increment 0.001°

Suitable Rotary Table :

CNC-120R	CNC-200RB	CNC-400R	CNCMT-200
CNC-170RB	CNC-250R	CNC-500R	CNCMT-320
CNC-170R	CNC-250RB	CNC-630R	NCF-250
CNC-200R	CNC-320R	CNC-800R	

ITEM	SPECIFICATION	ITEM	SPECIFICATION
Min. Increment	0.001°	Key-Lock Function	Set Parameter #7 to (0)
Programmable Angle	0+/-359.999°		
Max. Equal Dividing	0+/-359.999°		
Emergency Stop	Whole system stop	Mode Selection After Power On	Program mode / Run mode
Input System	key board or RS232C	Backlash Adjustment	Parameter number # 10
Zero Return	Can be compensated by hardware / software	Previous Step Display Function	Pushing "F1" key
Feed rate	1~999.9 deg / sec	Next Step Display	Pushing "J" key
Program Capacity	10 Programs, 99 steps for each program	Standard Parameter	Parameter PA01-26, PA50-66 can be set easily
Jump Function	Jump to sub-program	Compensation Function of Encoder	Optional PA48=2
Loop Count	Up to 999 times per step		

Example

Step 1	Turn (Power) switch on.	Step 5	Push PROG to feed-rate (F), input "30"
Step 2	Push and hold PROG and release display becomes blinking	Step 6	Push FUNC to loops (L), input "4"
Step 3	Push and hold CLR for 5 sec. or "00" display	Step 7	Push PROG display become no blinking
Step 4	Key in "9000"	Step 8	Push START table start rotating 4 times

NO. SPECIFICATION

1	Program step display : Present the step number	
2	Data display : To show either position, step angle, feedrate or count	
3	Led Indicator : There are 8 LED indicators on the control panel.	
4	"STEP/PROG" KEY : During either run or program mode this key is used touches other programs. Press this key and the "Program" & "Step" number flash.	
5	"MODE KEY" : This key toggles the control between run and program mode.	
6	"INS" KEY (INSERT) Insert a program step into memory in program mode.	
7	"RIGHT ARROW KEY" : This key has the following functions: a. In both run and program mode it changes the control display from "P","S","F","L","P","S"...Entries. b. In program mode for parameter entry it scrolls display through parameter settings. c. Scrolling or directing programmer or parameter access.	
8	"UP ARROW KEY" : Scrolls the program up through steps or up through parameters.	
9	"DOWN ARROW KEY" : Scrolls the program up through steps or through parameters.	
10	NUMERIC KEYS(0 to 9) : Data entered has the numeric or mathematical face value of key pressed. "+/-" KEY (PLUS / MINUS) : this key has 2 functions: a. Sets the motor running direction in program mode for an incremental move. b. Selects the alpha "Op Code" (a through d) during program mode. During op code selection press the "+/-" key scrolls the program from op code A to op code D.	
11	"STOP KEY" : Press this key stops program execution or motor running. During motor running press the "STOP" key once-motor stops and the stop "LED" lights. Press the "Start" key to continue the remaining unexcited portion of this step. But, if another key is pressed or the "STOP" key is pressed again the unexcited portion of the step is lost. Press the "Start" key now executes the current full-programmed step again.	
12	"START KEY" : This key is functional only in the "RUN" mode. When this key is pressed the current step shown on display will be executed. For the duration of the motor running or program executing the "LED" above the "Start" key is illuminated. This "Start" key and the "Remote Start" signal perform the same function-that is initiating a motor moving.	
13	"Home KEY" : The home functions are defined in parameters PA11, PA12 and PA13. (See the parameter section). parameter 04 establishes the "ZERO" or "HOME" speed and parameter 01 establishes the home acceleration or deceleration values.	
14	"Zero KEY" : Pressing this key returns the motor to the absolute zero position. Parameter 04 establishes the "ZERO" or "HOME" speed and parameter 01 establishes the "ZERO" acceleration or deceleration values.	
15	"JOG" AND "-JOG" KEY : Holding either of these 2 keys down causes the motor rotate in the corresponding direction. Parameter 03 establishes the jog speed and parameter 02 establishes the jog acceleration or deceleration values.	

NO. SPECIFICATION

1	Motor Connection : The motor connector is 14 pin MS type with part no MS3-102A-20-27S.	
2	Encoder Connection : The motor connector is 10 pin MS type with part no MS3-102A-18-1P.	
3	Interface Signal : The interface connector is 17 pin MS type with part no MS-3102A-20-29P.	
4	Hand Wheel Connection : Please also see PA24 for further detail about the hand wheel control.	
5	RS232C Connection : The RS232C connector is a 9 pin D type connector. pin 2 and pin 3 / pin 7 and pin 8 are exchanged inside the controller. So, please use a one to one connection cable for this connector.	
6	Faceplate Encoder Connection : The faceplate encoder is an option only for those models, which have dual feedback feature.	
7	Brake Solenoid (DC24V)	
8	AC Power Input : Please supply 110V/220 VAC with minimum 10 Amp to this power socket.	
9	Fuse 10A/15A : Please use a 10A/15 Amps rating current / 3 cm / slow blow main fuse for this controller.	
10	FG	

CNC



- ◎ Use LED backlight 5.7-inch monitor
- ◎ Chinese / English subtitles, easy operation.
- ◎ Connecting with M-Code of CNC M/C (Any Brand)
- ◎ Adopting AC servo systems to perform in high-precision, high speed, large torque
- ◎ To match any brand of servo motors such as : Yaskawa, Mitsubishi, Delta, TECO
- ◎ To offer 36 sets compensation for backlash adjusting, every 10 degrees compensation once to achieve the best accuracy
- ◎ Optional HEIDENHAIN encoder to be closed-loop system
- ◎ Optional MPG hand wheel for workpiece adjusting

CNCB

CNCT / CNCMT

NCF

Tailstock

Large Size Table

GCT

PT

APCR / APCI

Controller

Coupling

Accessories

ITEM	SPECIFICATION	ITEM	SPECIFICATION
Min. Increment	0.001°	Backlash Adjustment	Adjusted by parameter screen 1 of 2
Programmable Angle	0.000~999.999 °	Standard Parameter Function	Input / Output interface, long press "."
Emergency Stop	Whole system stop	Programmable System	Accepted incremental / absolute value
Input Method	Keyboard input	Instruction Selecting	Program input instruction / Indexing and rotating instruction
Program Capacity	15 sets of program	Origin Adjustment	Origin offset compensation setting
Program Step Capacity	90 steps for each program	External start signal	Automatic operation by M-CODE
Homing	Machine homing / relative homing	Delay time	0.1 to 99.9 seconds of delay
Jump Function	Jump to the subroutine (JUMP)	Input Power	Three-phase AC-220V 50/60HZ
Cycle Loop	Step up to 999 times per cycle	Connection cable	Power cable / Motor cable / CNC connection cables

1	1. The angle of rotary table
2	2. Executing instruction
3	3. The speed of rotary table Example
4	4. Display executing step
5	5. Program instructions
6	6. Executing angle
7	7. The number of execution times
8	8. Executing speed
9	9. Current status

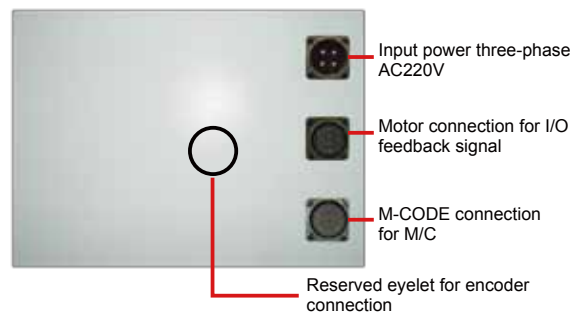

Program example (a circle drilling four holes, method of equal amount (90° degrees)) (program screen as shown below)

Step 1	Turn on the power	Step 5	Input numeric key for setting speed
Step 2	Press SCR key to enter the program edit screen	Step 6	Input 4 of numeric keys to enter (division into four units)
Step 3	Press 2 of numeric key to enter	Step 7	Press the MODE key to return main screen
Step 4	Input 360 (degrees) of numeric key to enter	Step 8	Press START key for operation

	Power switch		Back to the execution screen
	Emergency stop button		Page key: switching program page
	MPG(hand wheel) socket		Jog key: select the direction for table rotating
	Screen for info displayed		Cursor key: direction selecting
	Stop key		Switching key for system screen
	Numeric keys: enter the program and parameters		Selection key for program OP
	I. To be decimal point while program setting or parameter status II. Program code setting: press key 2 seconds while the program STEP1 of OP		Return to relative origin
	"+" and "-" key: be the function while program setting or parameter status"		Return to mechanical origin
	Insert a program while program setting		Enter key
	I. Long press 3 seconds for setting 0 degree of table while the execution status II. Delete a program while program setting		Start key



3 PCS HIRTH COUPLING

- ◎ We offer all kinds of specifications which including 24T, 36T, 40T,48T, 60T, 72T, 360T, besides special orders also acceptable.
- ◎ Use SCM21 material, after heat treating it has high rigidity & durable impact force.
- ◎ High accuracy, interchangeable.
- ◎ Indexing accuracy: ±3 sec, repeatability: ±1 sec.
- ◎ High QC inspection, accuracy remains the same after long term use.

Reference Chart of Roatry Table DIA. & Hirth Coupling O.D.

Rotary Table DIA	Ø300	Ø400	Ø500	Ø630	Ø800	Ø1000
Coupling O.D.	Ø250	Ø320	Ø400	Ø450	Ø600	Ø800

DIMENSION

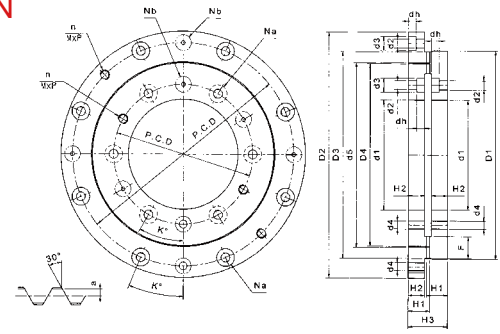

COMPARISON CHART BETWEEN ANGLE ACCURACY & LINEAR TOLERANCE

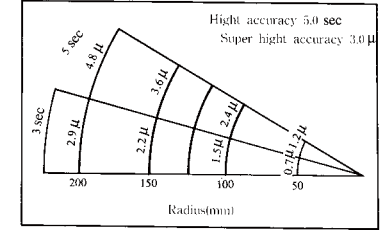

NO.	Model NO.	Outside DIA	Outside DIA	Inside DIA	Number of teeth	Teeth profile	Topend thickness of teeth	Inside thickness	Total thickness	Fixed bolt hole				Positioning pin hole			Withdraw bolt hole			Pitch of top end	Allowance of pitch top end		
										Number of holes	P · C · D	Hole DIA	Top DIA	Depth of hole	Number of pin hole	P · C · D	Angle of hole	Hole DIA	Number of teeth hole			P · C · D	Spec. of teeth
1	024135-060	135	-	60	24	18	18.75	13.5	34	6	80	6.6	11	6.0	3	80	30°	8	2	80	M8x1.25	1.75	1.55
2	024200-120	200	-	120	24	20	21.75	16.5	40	8	140	9.0	14	8.0	3	140	22.5°	8	2	140	M8x1.25	1.75	1.55
3	030200-120	200	-	120	30	20	21.75	16.5	40	8	140	9.0	14	8.0	3	140	22.5°	8	2	140	M8x1.25	1.75	1.55
4	0360250-180	250	-	180	360	8	20.2	18	40	12	205	11.0	17.5	10.0	3	205	15°	10	2	205	M10x1.5	0.2	0.17
5	024270-160	270	-	160	24	24	21.75	16.5	40	8	195	11.0	17.5	10.0	3	195	22.5°	10	2	195	M10x1.50	1.75	1.55
6	030270-160	270	-	160	30	24	21.75	16.5	40	8	195	11.0	17.5	10.0	3	195	22.5°	10	2	195	M10x1.50	1.75	1.55
7	0360270-160	270	-	160	360	10	20.2	18	40	12	300	M14	20	12.5	3	300	15°	12	4	300	M12x1.75	1.75	1.55
8	048335-220	335	-	220	48	24	25.75	20.5	48	12	258	13.0	20	12.0	3	258	15°	12	4	258	M12x1.75	1.75	1.55
9	048425-300	425	-	300	48	28	26.75	21.5	50	12	335	13.0	20	12.0	3	335	15°	12	4	335	M12x1.75	1.75	1.56
10	060425-3000	425	-	300	60	28	26.75	21.5	50	12	335	13.0	20	12.0	3	335	15°	12	4	335	M12x1.75	1.75	1.55
11	072425-300	425	-	300	72	28	26.75	21.5	50	12	335	13.0	20	12.0	3	335	15°	12	4	335	M12x1.75	1.75	1.55
12	0360425-300	425	-	300	360	20	26	21.5	50	12	450	13.0	20	12.0	3	450	15°	12	4	450	M12x1.75	1	0.9
13	048540-415	540	-	415	48	32	29.25	24.0	55	12	450	13.0	20	12.0	3	450	15°	12	4	450	M12x1.75	1.75	1.55
14	060540-415	540	-	415	60	32	29.25	24.0	55	12	450	13.0	20	12.0	3	450	15°	12	4	450	M12x1.75	1.75	1.55
15	072540-415	540	-	415	72	32	29.25	24.0	55	12	450	13.0	20	12.0	3	450	15°	12	4	450	M12x1.75	1.75	1.55
16	0360540-415	540	-	415	360	24	29	24.0	55	12	570	17.0	26	16.5	3	570	15°	12	2	450	M12x1.75	1.5	1.4



2 PCS HIRTH COUPLING

DIMENSION

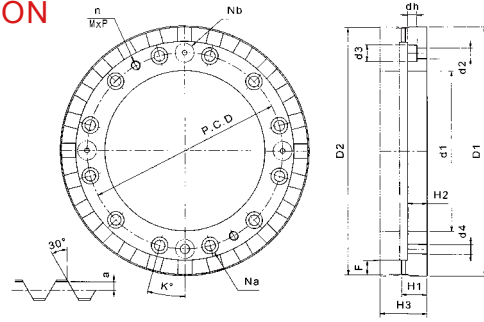

NO.	Model NO.	Outside DIA.		Inside DIA.	Number of teeth	Teeth profile	Topend thickness of teeth	Inside thickness			Fixed bolt hole				Positioning pin hole				Withdraw bolt hole		Pitch of top end	Allowance to pitch top end	
		D1	D2					H1	H2	H3	Number of holes	d	D	Hole DIA.	Top DIA.	Depth of hole	Number of pin hole	d	D	Hole DIA.			Number of teeth hole
					N	F	H1	H2	H3	Na	d2	d3	dh	Nb	K	d4	n	Mxp	a				
1	24080-44XV	80	79	44	24	8	15.30	12.0	29	6	60	M8	11.0	8.8	4	55	30°	Ø2	6	60	M8x1.25	2	1.8
2	20100-40XV	100	98	40	20	9	18.37	14.0	34	6	60	6.6	11.0	6.0	3	60	30°	8	2	60	M8x1.25	1.37	1.22
3	24100-40XV	100	98	40	24	8	18.30	14.0	34	6	60	6.6	11.0	6.0	3	60	30°	8	2	60	M8x1.25	1.3	1.15
4	24120-60XV	120	118	60	24	8	18.30	14.0	34	6	80	6.6	11.0	6.0	4	80	30°	8	2	80	M8x1.25	1.3	1.15
5	30120-60XV	120	118	60	30	7	19.3	14.0	34	6	80	6.6	11.0	6.0	4	80	30°	8	2	80	M8x1.25	2.3	2
6	36140-80XV	140	138	80	36	11	18.52	14.0	34	6	100	6.6	11.0	6.0	3	100	30°	8	2	100	M8x1.25	2.5	2.2
7	24160-100XV	160	158	100	24	9	21.73	16.5	40	8	118	9.0	14.0	8.0	4	118	22.5°	10	2	118	M8x1.25	2.5	2.3
8	24180-120XV	180	178	120	24	9	21.61	16.5	40	8	140	9.0	14.0	8.0	3	140	22.5°	8	2	140	M8x1.25	1.61	1.44
9	36180-120XV	180	178	120	36	9	21.37	16.5	40	8	140	9.0	14.0	8.0	3	140	22.5°	8	2	140	M8x1.25	1.37	1.22
10	40180-120XV	180	178	120	40	9	21.76	16.5	40	8	140	9.0	14.0	8.0	3	140	22.5°	8	2	140	M8x1.25	1.76	1.57
11	24200-120XV	200	198	120	24	9	21.63	16.5	40	8	150	9.0	14.0	8.0	4	150	22.5°	8	2	150	M8x1.25	1.63	1.45
12	36200-120XV	200	198	120	36	11	21.52	16.5	40	8	150	9.0	14.0	8.0	3	150	22.5°	8	2	150	M8x1.25	1.52	1.36
13	72200-120XV	200	198	120	72	9	20.99	16.5	40	8	150	9.0	14.0	8.0	3	150	22.5°	8	2	150	M8x1.25	0.99	0.89
14	48210-135XV	210	208	135	48	13	21.71	16.5	40	12	165	9.0	14.0	8.0	3	158	15°	10	2	165	M8x1.25	1.71	1.53
15	60250-160XV	250	248	160	60	9	21.63	16.5	40	8	195	11.0	17.5	10.0	3	195	22.5°	10	2	195	M10x1.50	1.63	1.45
16	72250-160XV	250	248	160	72	11	21.42	16.5	40	8	195	11.0	17.5	10.0	3	195	22.5°	10	2	195	M10x1.50	1.42	1.27
17	360250-160XV	250	248	160	360	7	20.5	16.5	40	8	195	11.0	17.5	10.0	3	195	22.5°	10	2	195	M10x1.50	0.5	0.4
18	72280-190XV	280	278	190	72	11	21.42	16.5	40	8	222	13.0	20.2	12.0	3	222	22.5°	10	2	222	M10x1.50	1.42	1.27
19	360280-190XV	280	278	190	360	8	20.6	16.5	40	8	222	13.0	20.2	12.0	4	222	22.5°	10	2	222	M10x1.50	0.6	0.5
20	60320-210XV	320	318	210	60	11	30.46	25.5	58	10	258	13.0	20.2	12.0	4	258	18°	12	4	258	M12x1.75	1.46	1.30
21	72320-210XV	320	318	210	72	11	30.74	25.5	58	12	258	13.0	20.2	12.0	3	258	15°	12	4	258	M12x1.75	1.74	1.55
22	360320-210XV	320	318	210	360	9	29.6	25.5	58	12	258	13.0	20.2	12.0	3	258	15°	12	4	258	M12x1.75	0.6	0.5
23	48400-280XV	400	398	280	48	13	31.52	26.0	60	12	335	13.0	20.2	12.0	3	335	15°	12	4	335	M12x1.75	1.52	1.36
24	60400-280XV	400	398	280	60	15	31.82	26.0	60	12	335	13.0	20.2	12.0	3	335	15°	12	4	335	M12x1.75	1.82	1.62
25	72400-280XV	400	398	280	72	13	31.52	26.0	60	12	335	13.0	20.2	12.0	3	335	15°	12	4	335	M12x1.75	1.52	1.36
26	360400-280XV	400	398	280	360	13	30.6	26.0	60	12	335	13.0	20.0	12.0	3	335	15°	12	4	335	M12x1.75	0.6	0.5
27	48520-415XV	520	518	415	48	15	31.97	26.0	60	12	450	13.0	20.2	12.0	3	450	15°	12	4	450	M12x1.75	1.97	1.76
28	72520-415XV	520	518	415	72	15	31.97	26.0	60	12	450	13.0	20.2	12.0	3	450	15°	12	4	450	M12x1.75	1.97	1.76
29	360520-415XV	520	518	415	360	15	30.8	26.0	60	12	450	13.0	20.2	12.0	3	450	15°	12	4	450	M12x1.75	0.8	0.7
30	60600-480XV	600	598	480	60	15	36.95	29.0	70	12	530	17.0	26.0	16.0	4	530	15°	12	4	530	M12x1.75	1.95	1.74
31	72600-480XV	600	598	480	72	19	37.28	29.0	70	12	530	17.0	26.0	16.0	3	530	15°	12	4	530	M12x1.75	2.28	2.04
32	360600-480XV	600	598	480	360	15	36	29.0	70	12	530	17.0	26.0	16.0	3	530	15°	12	4	530	M12x1.75	1	0.9
33	72700-560XV	700	698	560	72	19	36.70	29.0	70	12	610	17.0	26.0	16.0	3	610	15°	14	4	610	M12x1.75	1.70	1.50
34	360700-560XV	700	698	560	360	19	36	29.0	70	12	610	17.0	26.0	16.0	3	610	15°	14	4	610	M12x1.75	1	0.9
35	721000-830XV	1000	998	830	72	22	61.70	54.5	120	18	900	17.0	26.0	16.0	4	900	10°	-	4	900	M12x1.75	1.70	1.50
36	3601000-830XV	1000	998	830	360	22	61.5	54.5	120	18	900	17.0	26.0	16.0	4	900	10°	-	4	900	M12x1.75	1.75	1.4
37	721200-1000XV	1200	1198	1000	72	22	71.70	64.5	140	20	1080	21.0	32.0	20.0	4	1080	9°	-	4	1080	M16x2.00	1.70	1.50
38	3601200-1000XV	1200	1198	1000	360	22	71.6	64.5	140	20	1080	21.0	32.0	20.0	4	1080	9°	-	4	1080	M16x2.00	1.6	1.5

Accessories Connection Diagram

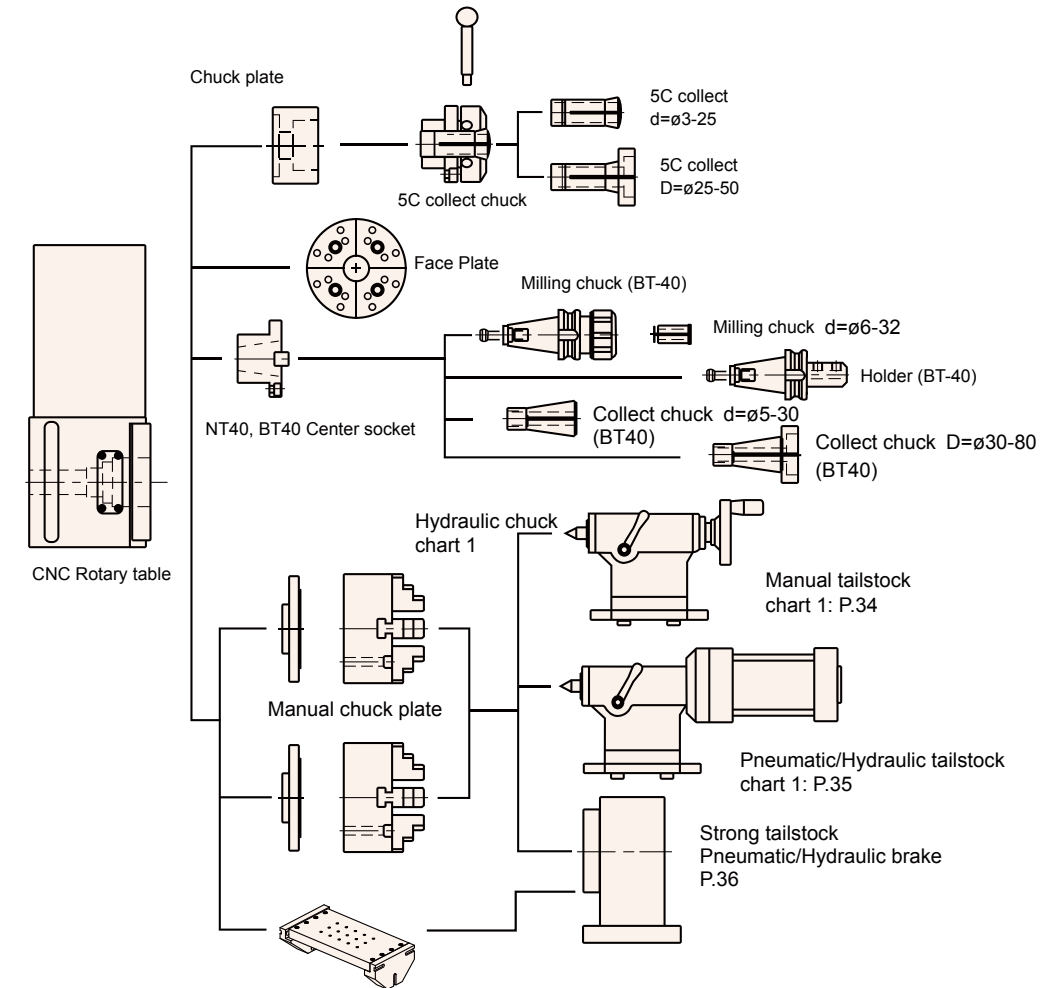
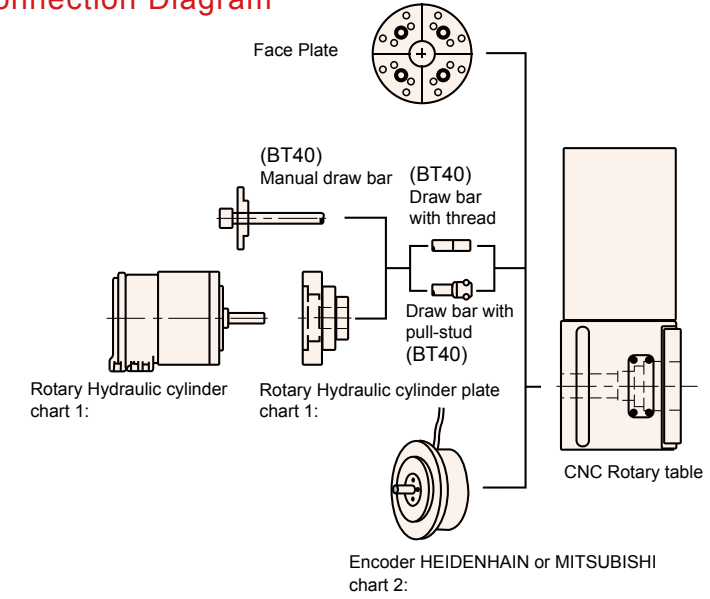

CNC

CNCB

CNCT
/
CNCMT

Chuck / Hydraulic Cylinder / Tailstock with Rotary Table Application

Chart 1

Suitable Rotary Table		CNC-120R	CNC-170R	CNC-200R	CNC-250R	CNC-320R	CNC-400R	CNC-500R	CNC-630R	CNC-800R
Manual Scroll chuck	Model NO.	SC-4	SC-6	SC-7	SC-8	SC-10	SC-12	SC-12	SC-12 SC-16	SC-12 SC-16
	Size	4"	6"	7"	8"	10"	12"	12"	12" 16"	12" 16"
Hydraulic chuck (Non Through hole)	Model NO.	V-206	V-206	V-206	V-208	V-210	V-212	V-212	V-215 V-218	V-215 V-218
	Size	6"	6"	6"	8"	10"	12"	12"	15" 18"	15" 18"
Rotary Hydraulic cylinder	Model NO.	MH100	MH100	MH100	MH125	MH125	MH150	MH150	MH200	MH200
Tailstock Type	Manual	TS-A115	TS-A135	TS-A160	TS-B185	TS-B210	TS-B250	TS-C310	TS-C400	TS-C480
	Pneumatic	TS-A115P	TS-A135P	TS-A160P	TS-B185P	TS-B210P	TS-B250P	TS-C310P	TS-C400P	TS-C480P
	Hydraulic	TS-A115H	TS-A135H	TS-A160H	TS-B185H	TS-B210H	TS-B250H	TS-C310H	TS-C400H	TS-C480H
	Strong (P/H)	TSA-120S	TSA-200S	TSA-200S	TSA-251S	TSA-251S TSA-320S	TSA-251S TSA-320S	TSA-320S	TSA-320S	TSA-320S

- ※ SC series is 3-jaw scroll chuck and internal and external jaws can be used interchangeably.
- ※ SIC series is 4-jaw scroll. Gripping of square or octagonal workpieces could fit into central line automatically. SIC series has high stability in gripping thin tube workpieces.
- ※ SK series is 3-jaw strong scroll chuck. The hard jaws are suitable for heavy cutting and soft jaws suitable for light and precision cutting. The hard jaws could be used as internal and external jaws.
- ※ SIK series is 4-jaw strong scroll chuck. The hard jaws are adopted for square or octagonal thin tube workpieces machining. The soft jaws could grip rectangular workpiece after being unisotropic machined.

GCT

PT

APCR
/
APCI

Controller

Coupling

Accessories



Accuracy of Table and Encoder

Chart 2

	Encoder Accuracy	Table Accuracy
RON275 RON285 RCN223	±5"	10"
RON287C RCN227F	±2.5"	7"
RON886	±1"	5"

CNC

CNCB

CNCT
/
CNCMT

NCF

Tailstock

Large
Size
Table

GCT

PT

APCR
/
APCI

Controller

Coupling

Accessories



Motor Torque Chart

STALL TORQUE	1Nm	2Nm	3Nm	4Nm	8Nm	12Nm	22Nm	30Nm	40Nm
FANUC	α 1/5000i	α 2/5000i	α 3/5000i	α 4/4000i	α 8/3000i	α 12/3000i	α 22/3000i	α 30/3000i	α 40/3000i
	SVM1-20i			SVM1-40i		SVM1-80i		SVM1-120i	SVM1-160i
					α c4/3000i	α c8/2000i	α c12/2000i	α c22/2000i	
					β 4/4000i	β 8/3000i	β 12/3001is	β 22/3001is	
				β SVM1-20i		β SVM1-40i			
SIEMENS	1FK7042		1FK7060	1FK7063	1FK7083	1FK7101	1FK7103	1FK7105	
MITSUBISHI	HF-75T	HF-54T	HF-104T	HF-154T	HF-204S	HF-354S	HF-453S	HF-703S	
HEIDENHAIN	QSY96A	QSY96G	QSY116C		QSY116E	QSY155B,C	QSY155D	QSY155F	QSY190D

- ※ Please choose the suitable characteristics (stall torque, MAX. torque and rotor inertia etc.) of the servo motors according to different size of CNC rotary table.
- ※ Other servo motor can be installed, please inform dimension and specification of servo motor in advance.
- ※ MAX. R.P.M of the servo motor(CNC rotary table) is decided from the acceleration characteristics of the servo motor and the practical load test.

(1)Hydraulic Unit



(2)PHC Booster



(3)Jig Fixture

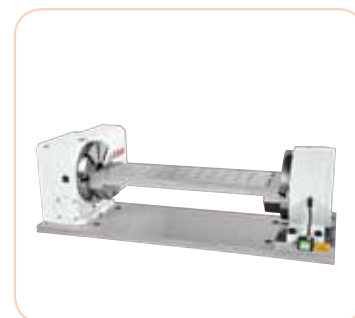



CNC-200R
Application : Vertical Machining Center

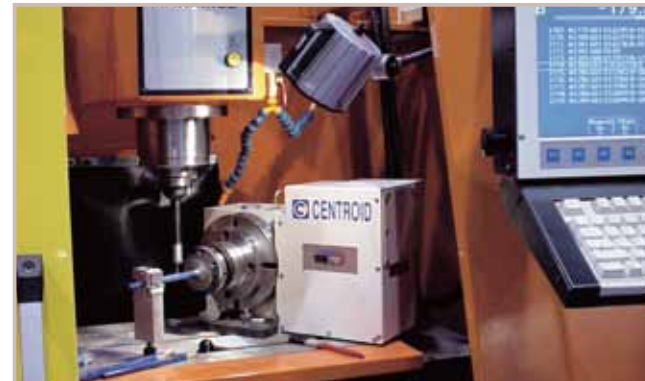

CNC-200R
Application : Vertical / Horizontal Machining Center



NCF-400 + TSA-251S(Strong Tailstock)
Application : Vertical / Horizontal Machining Center

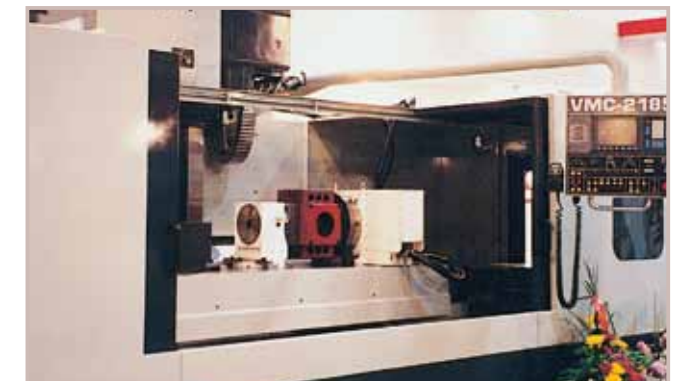

NCF-400 + TSA-251S (Special tailstock + 4 faces fixture plate)
Application : Vertical / Horizontal Machining Center

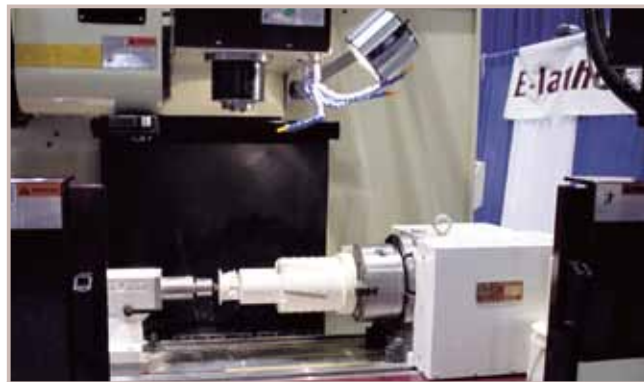

CNC-250R
Application : Vertical / Horizontal Machining Center



CNC-320R + TSA-320S(Strong Tailstock)
Application : Vertical Machining Center



CNCT-100
Application : Vertical Machining Center



CNCT-200
Application : Vertical Machining Center



CNC-320R
Application : Vertical Machining Center



CNC-320 + TS-B210(Tailstock)
Application : Vertical Machining Center



CNCT-450
Application : Vertical Machining Center



CNCT-800
Application : Large Size Machining Center



CNC-800R + G-Mate or M-Mate
Application : Horizontal Machining Center or Conventional Machine



CNC-1500RV
Application : Horizontal Machining Center

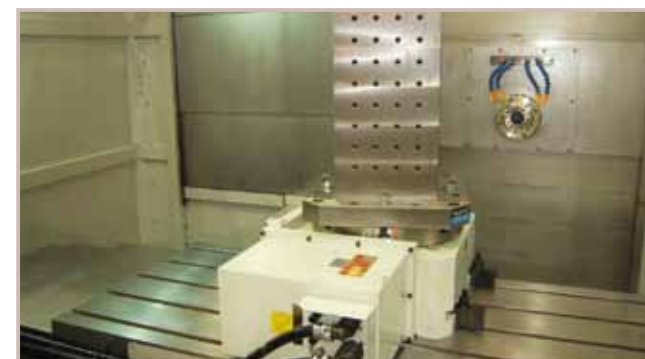

HIT-400
Application : Horizontal Machining Center



HRT-1500
Application : Horizontal Machining Center