

# Special milling with insert

All tools listed are only examples for individual groups tools, dimensions and shape can vary a lot depending on the specific assignment.

It always depends on your requirement, the given tool will be adapted to you measure, both by the machined shape, by choosing the corresponding insert, by the type of clamping to spindle, as well as by choosing suitable cutting conditions.

Special tools are used when the catalog tool is not enough shape of dimensions.

## The possible type of special milling tool:

- combined drilling and milling tools
- chamfer milling tools
- shape tools
- back countersinking tools
- angle milling tools
- tools for T-slot
- grooving and cut of milling
- tool according to your specifications

## Criteria for the design and construction of a special tool:

The basic input information for the design of a special tool is:

- machined geometry - the desired shape after machining
- machined material
- requirements for the quality of the machined surface
- machine - spindle - clamping method (arbour mounting, weldon, ...)
- other customer requirements

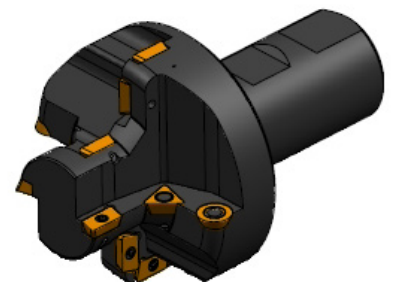
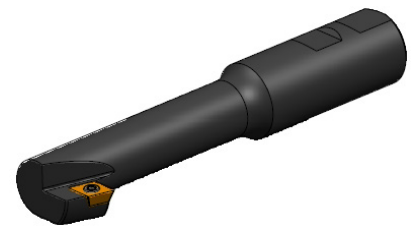
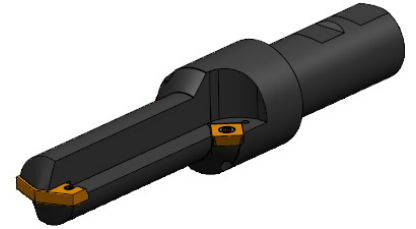

# Combined drilling and milling tools

Creates a hole of diameter  $D$  with a length (depth) of  $L$  while also creating a chamfer below the given one by an angle in the length of an edge or recess of a given diameter.

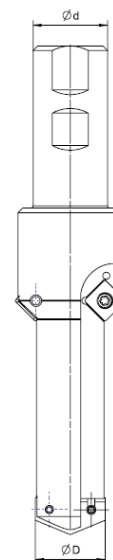
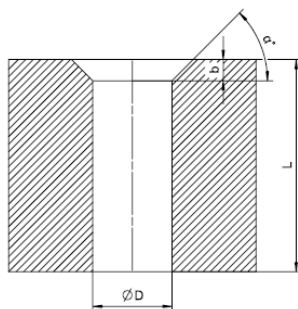
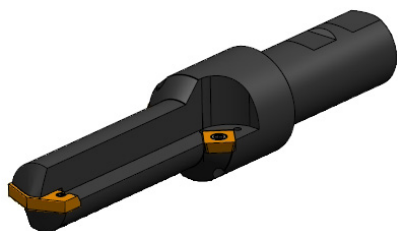

## Optional parameters:

- $\varnothing D$  – diameter of the drilled hole
- $b$  – length of chamfer
- $\varnothing d$  – clamping diameter
- $\alpha$  – angle of chamfer
- $L$  – hole depth

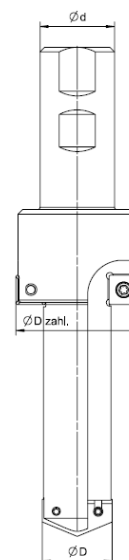
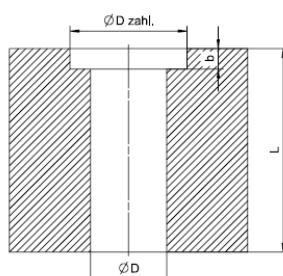
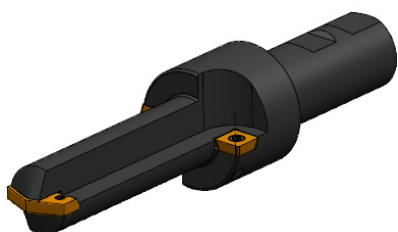

## Optional parameters:

- $\varnothing D$  – diameter of the drilled hole
- $L$  – hole depth
- $\varnothing D$  chamfer diameter
- $b$  – depth of chamfer
- $\varnothing d$  – clamping diameter

# Chamfer milling tools

Creates an edge chamfer at the given angle and dimension.  
The edges can also be cut backwards.

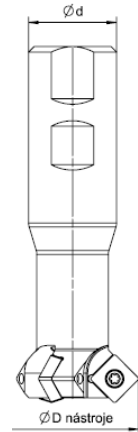
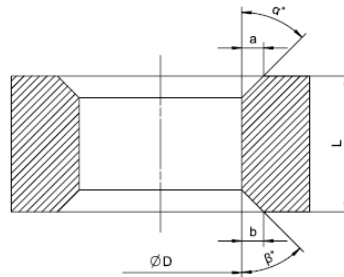

## Optional parameters:

- $\varnothing D$  – hole diameter
- $\varnothing d$  – clamping diameter
- $L$  – hole depth
- $\alpha$  – angle of chamfer 1
- $a$  – length of chamfer 1
- $\beta$  – angle of chamfer 2
- $b$  – length of chamfer 2

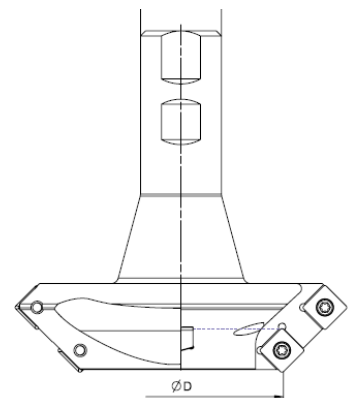
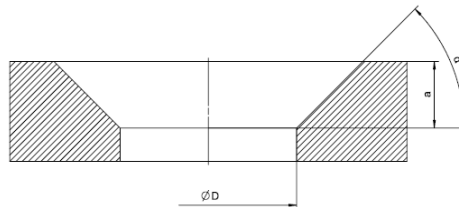

## Optional parameters:

- $\varnothing D$  – hole diameter/milling tool
- $\varnothing d$  – clamping diameter
- $\alpha$  – angle of chamfer
- $a$  – length of chamfer

# Shape tools

Shape tools sometimes combine several tools for streamlining production times.

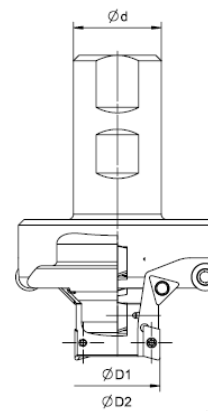
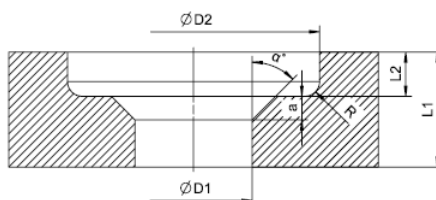
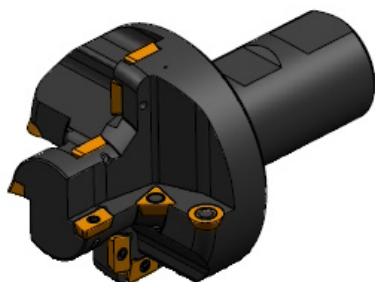

## Optional parameters:

- $\varnothing D1$  – hole diameter/milling tool
- $\varnothing D2$  – diameter milling tool 2
- $\varnothing d$  – clamping diameter
- $L1$  – depth of hole 1
- $L2$  – depth of hole 2
- $\alpha$  – angle of chamfer 1
- $a$  – length of chamfer 1
- $R$  – radius

# Back countersinking tools

The hard-to-reach places can be milled by back countersinking tools.

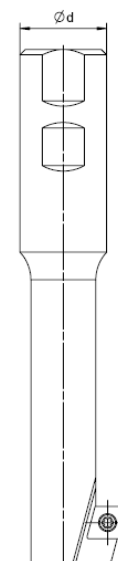
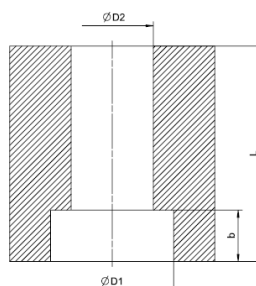
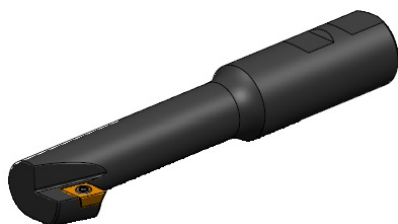

## Optional parameters:

- $\varnothing D1$  – diameter of the drilled hole
- $\varnothing D2$  – hole diameter
- $\varnothing d$  – clamping diameter
- $b$  – depth of chamfer

# Angle milling tools

Achieving angular surfaces using classic 3-axis machines.

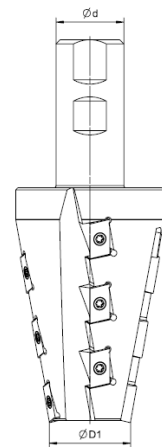
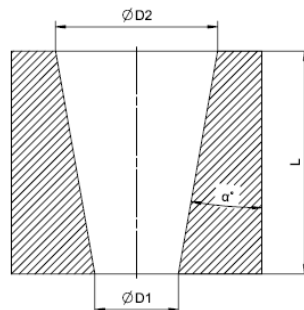

## Optional parameters:

- $\varnothing D1$  – diameter milling tool 1
- $\alpha$  – angle of chamfer
- $\varnothing D2$  – diameter milling tool 2
- $L$  – length of profile
- $\varnothing d$  – clamping diameter - weldon

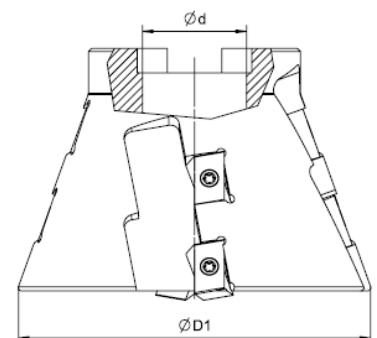
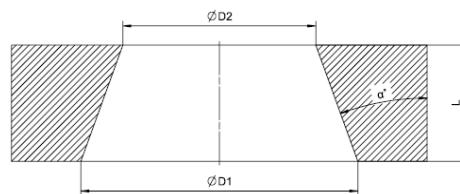
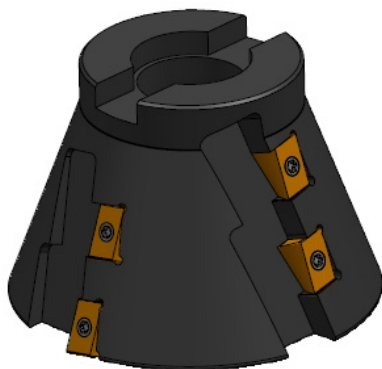

## Optional parameters:

- $\varnothing D1$  – diameter milling tool 1
- $\alpha$  – angle of chamfer
- $\varnothing D2$  – diameter milling tool 2
- $L$  – length of profile
- $\varnothing d$  – clamping diameter - arbor mounting

# Tools for T-slot

When the size or shape of the catalog tool is not enough.

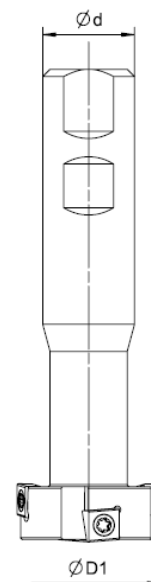
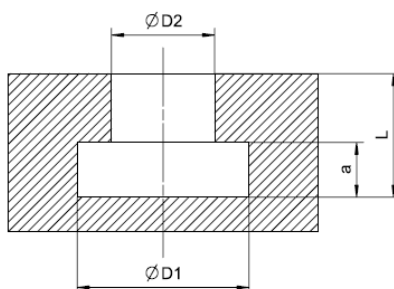

## Optional parameters:

- $\varnothing D1$  – diameter of profile / milling tool 1
- $\varnothing D2$  – diameter of profile / milling tool
- $\varnothing d$  – clamping diameter - arbor mounting
- $a$  – groove dimension
- $L$  – length of profile

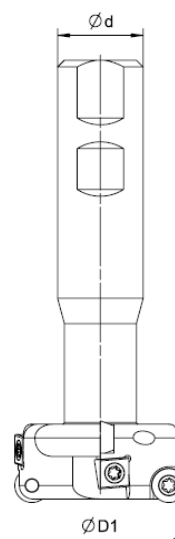
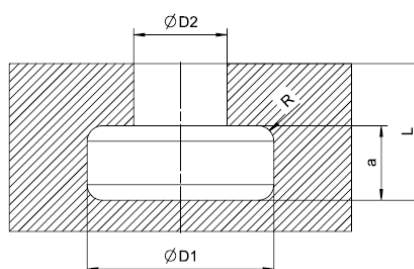

## Optional parameters:

- $\varnothing D1$  – diameter of profile / milling tool 1
- $\varnothing D2$  – diameter of profile / milling tool 2
- $\varnothing d$  – clamping diameter - arbor mounting
- $a$  – groove dimension
- $L$  – length of profile
- $R$  – radius of profile

# Grooving and cut of milling

Grooving and cut of milling diameter what you are looking for.

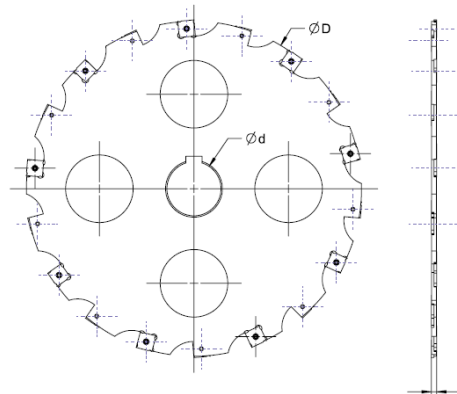

## Optional parameters:

- $\text{ØD1}$  – diameter of milling tool
- $\text{Ød}$  – clamping diameter - arbor mounting
- $b$  – tool width

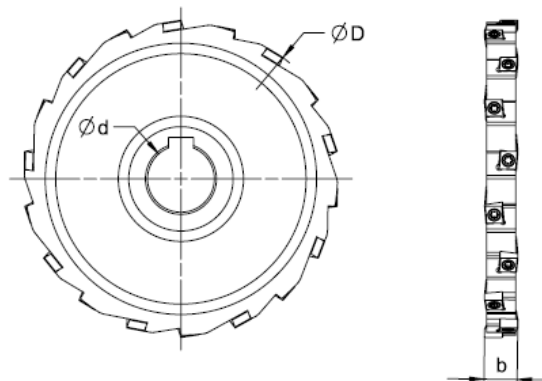
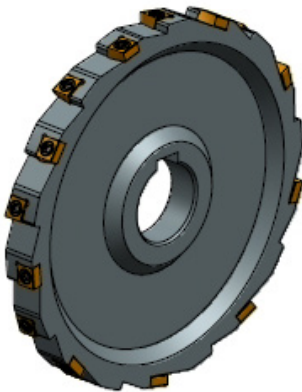

## Optional parameters:

- $\text{ØD1}$  – diameter of milling tool
- $\text{Ød}$  – clamping diameter - arbor mounting
- $b$  – tool width

# Tool according to your specifications

Did you not find a special tool in our catalog that would solve your problem?

## The basic input information for the design of a special tool is:

- machined geometry - the desired shape after machining
- machined material
- requirements for the quality of the machined surface
- machine - spindle - clamping method (arbour mounting, weldon, ...)
- other customer requirements